

**MANUALE DI ISTRUZIONI - INSTRUCTION MANUAL**

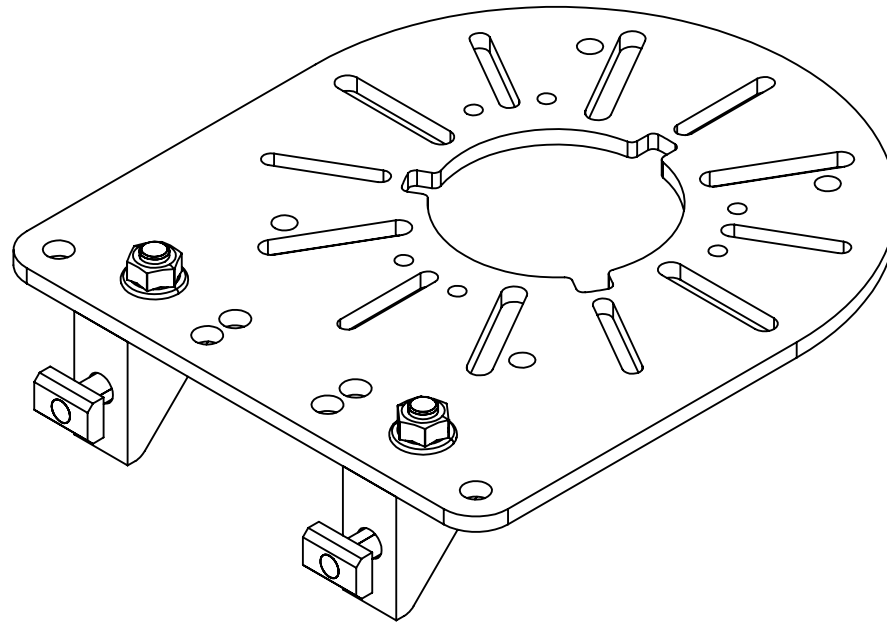

**UNIVERSAL BASS SHAKER MOUNT**

## PRIMA DI PARTIRE:

ITA- Grazie per aver acquistato questo prodotto Sim Factory!  
Nelle pagine seguenti troverete istruzioni dettagliate sull'assemblaggio.  
Ciò richiede degli strumenti semplici e un po' del vostro tempo.

A seconda del prodotto scelto l'assemblaggio può richiedere da qualche minuto a molte ore, ma adorerete ogni minuto speso per dar forma al vostro prodotto Sim Factory.

## BEFORE YOU START:

ENG- Thank you for purchasing this Sim Factory product!  
On the following pages, you will find detailed instructions on assembly.  
This requires only a set of simple tools and some of your time.

Depending on the product chosen assembly can take from a few minutes to many hours, but you will love every minute spent on shaping your Sim Factory product.

ITA- Strumenti necessari:

ENG- Tools needed:

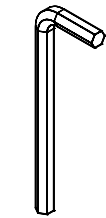

4mm  
5mm  
6mm

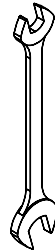

13mm  
17mm

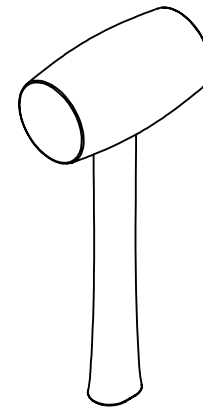

martello in gomma  
rubber hammer

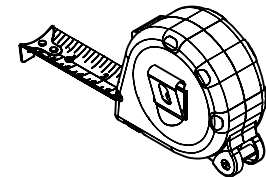

## Inserimento cursori:

ITA- In questo diagramma potete vedere come inserire un cursore direttamente nella cava. Potete anche usare una delle chiavi esagonali più piccole per aiutarvi a muovere il cursore in posizione.

## Inserting Slot-Nuts:

ENG- In this diagram, you can see how to insert a Slot-Nut directly into the slot from the side. You can also use one of your smaller Hex wrenches to help wiggle the Slot-Nut in place.

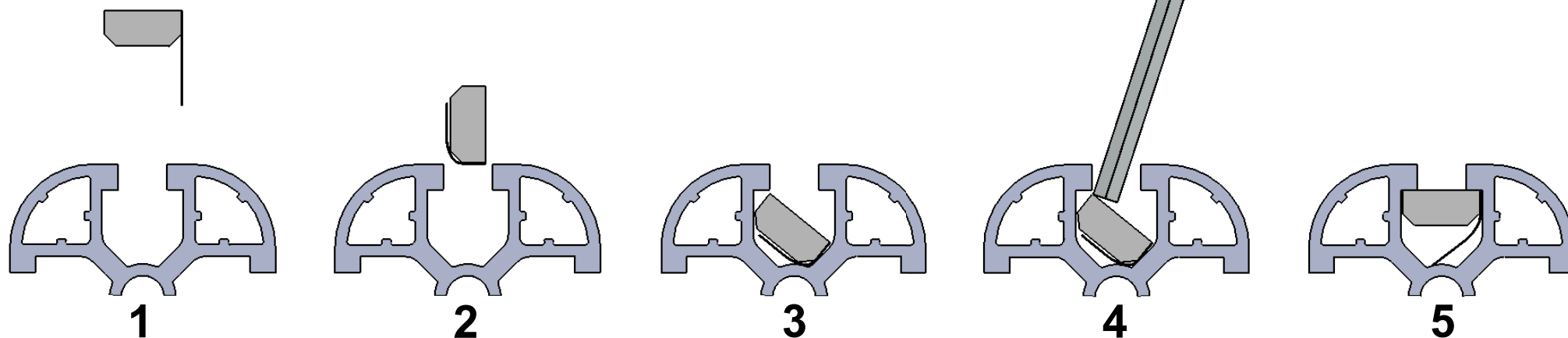
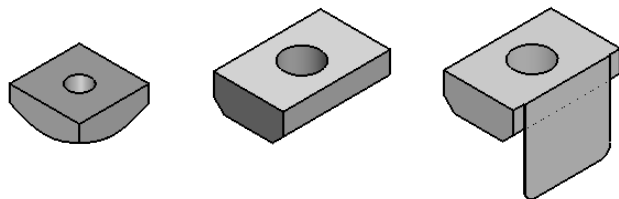

## Foro passaggio chiave:

ITA- In questo diagramma potete vedere come eseguire il fissaggio correttamente.

## Hex wrenches passage hole:

ENG- In this diagram, you can see how to fixing correctly.

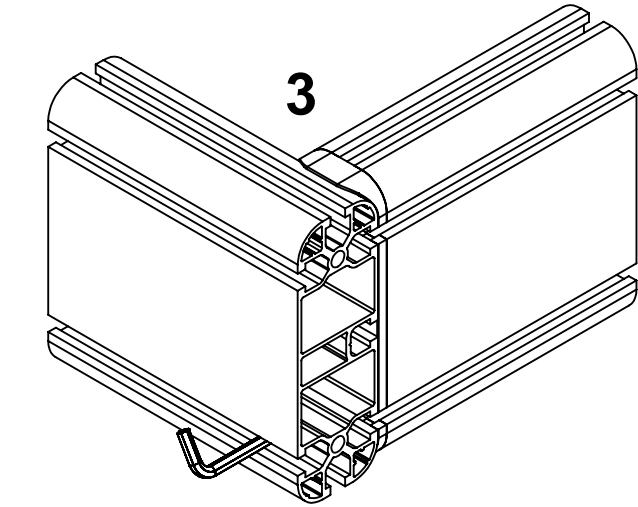
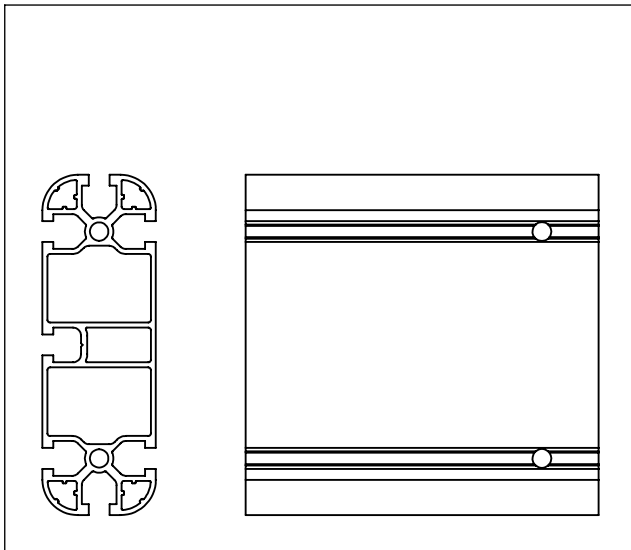
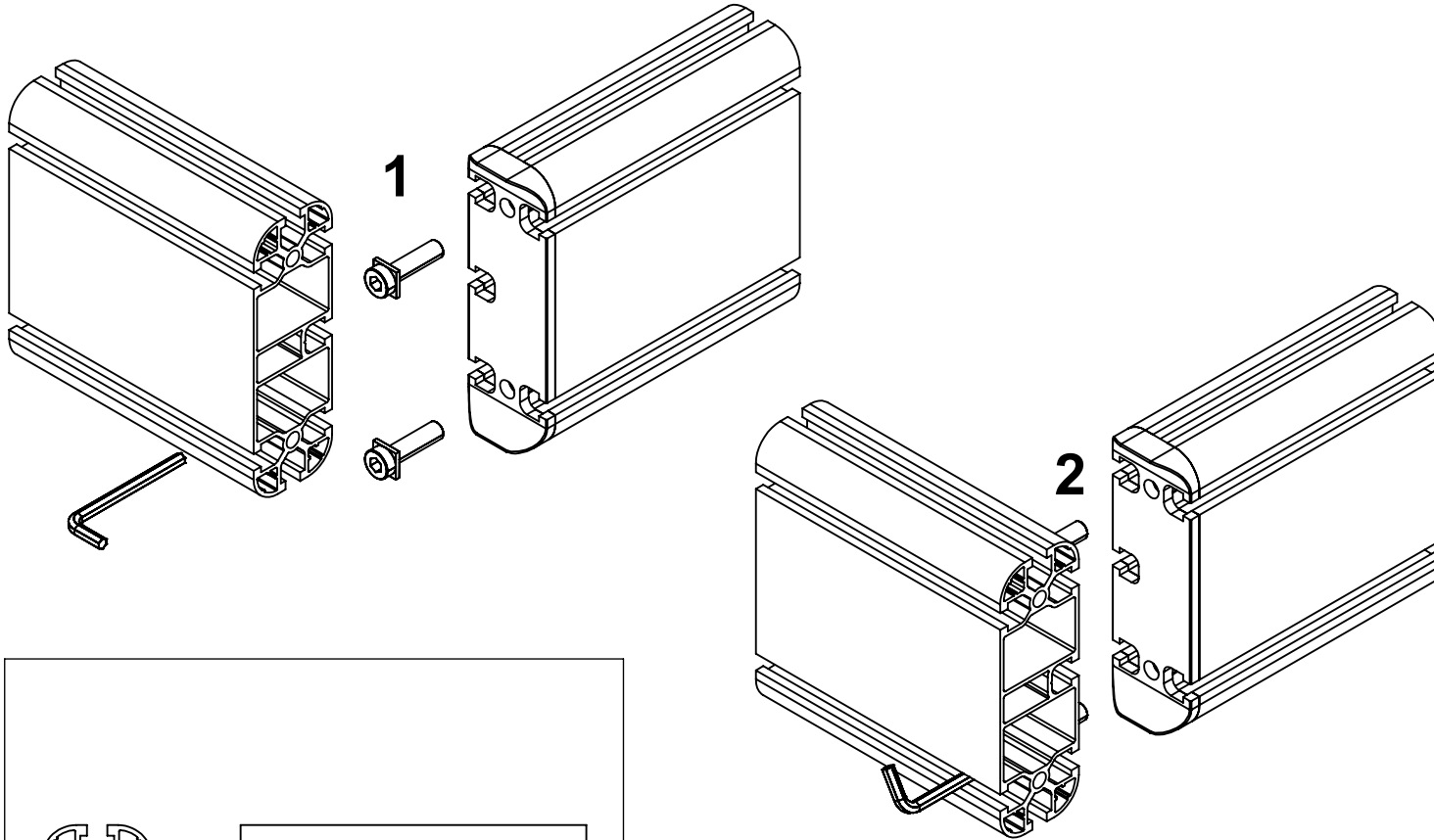

ITA- Vite a testa ribassata  
ENG- Low head screw

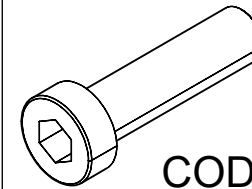

COD.CVITB0000023

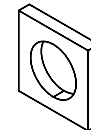

COD.CROY0000013

## Foro passaggio chiave:

ITA- In questo diagramma potete vedere un altro modo per eseguire il fissaggio.

## Hex wrenches passage hole:

ENG- In this diagram, you can see another way to do the fixing.

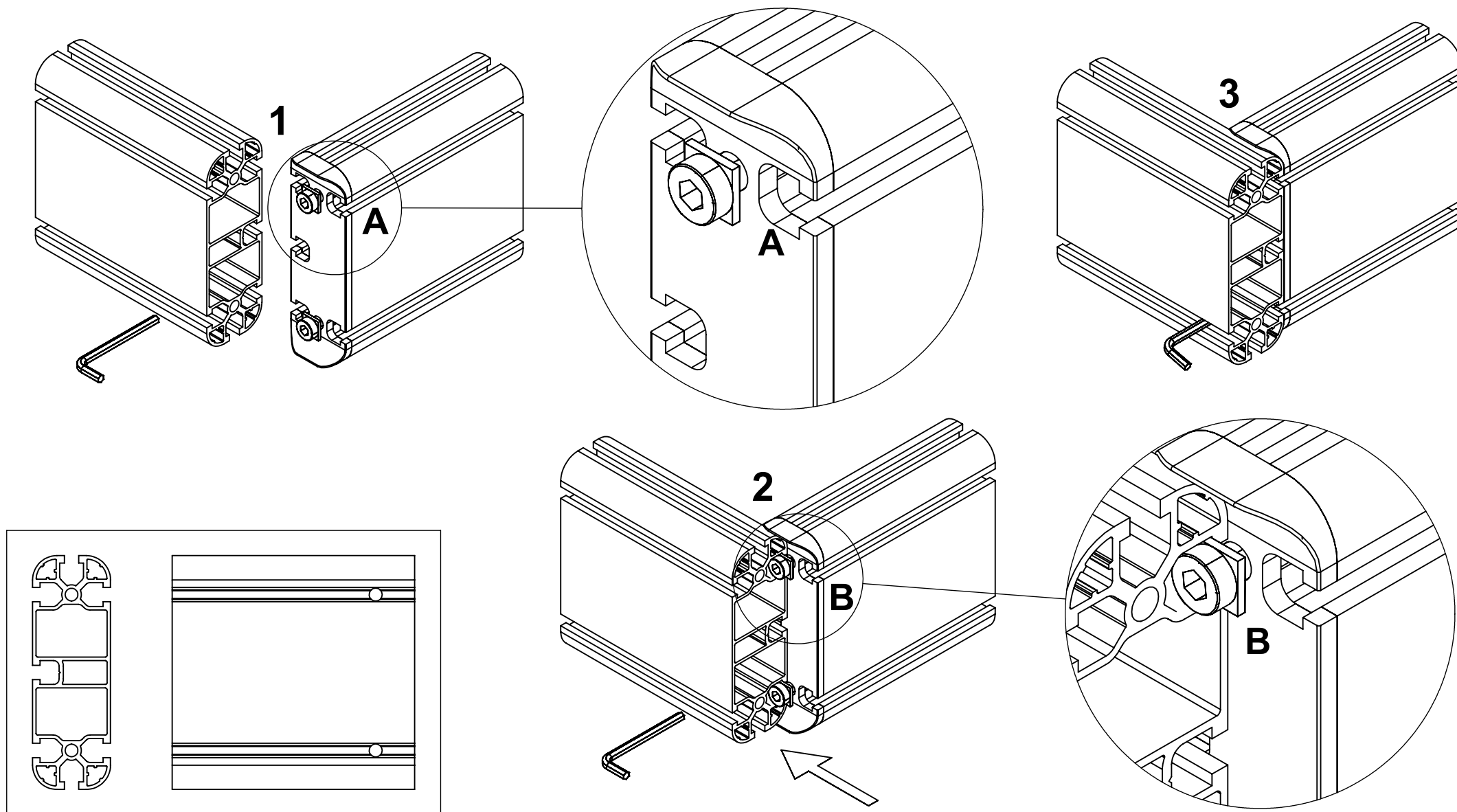

## Inserimento tappi e giunti:

ITA- In questo diagramma potete vedere come inserire un tappo o un giunto. Potete anche usare il martello in gomma per incastrare il tappo o il giunto. Colpite la parte piatta del giunto, non occorre molta forza.

## Inserting caps and joints:

ENG- In this diagram, you can see how to insert a cup or joint. You can also use the rubber hammer to tap in the cap or joint. Hit the flat part of the joint, it doesn't take much force.

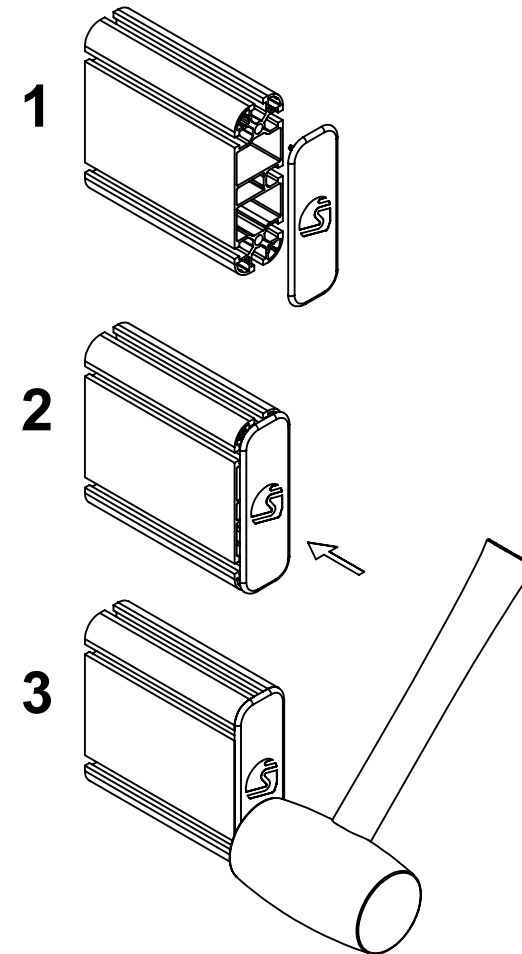
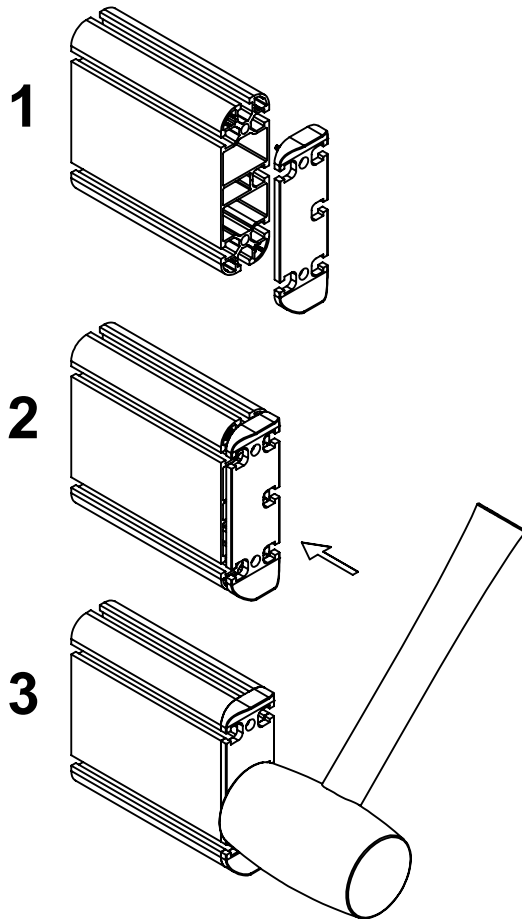

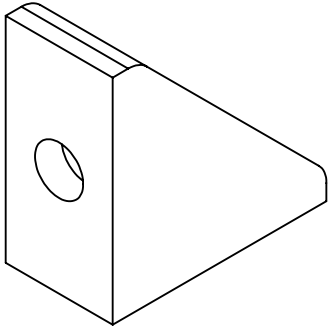
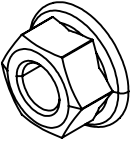
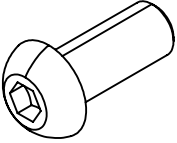
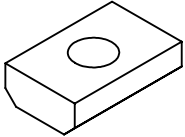
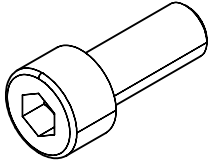
<b>DSQAL0000243</b> <b>2 PZ</b>  <b>SA.02.UBS.01</b>	<b>DIN 6923</b> <b>M8</b> <b>2 PZ</b>  <b>SA.01.UBS.01</b>	<b>ISO 7380</b> <b>M8X20</b> <b>2 PZ</b>  <b>SA.01.UBS.01</b>	<b>M8 13X20X6</b> <b>COD.DDDCU0000037</b> <b>4 PZ</b>  <b>SA.01.UBS.01</b>	<b>UNI 5931</b> <b>M8X20</b> <b>4 PZ</b>  <b>SA.01.UBS.01</b>	
					

**ITA- COSA C'È NELLA SCATOLA**  
**ENG- WHAT'S IN THE BOX**

**DIM: 35 X 35 X H 20**  
**WEIGHT: 1 KG**  
**COD: KI.UBS.01.N**

**UN.PI.05.11.N.ST** **1PZ**

**SA.01.UBS.01 :**

COD.DDDCU0000037 4PZ

ISO 7380 M8X20 2PZ

DIN 6923 M8 2PZ

UNI 5931 M8X20 4PZ

**SA.02.UBS.01 :**

DSQAL0000243 2PZ



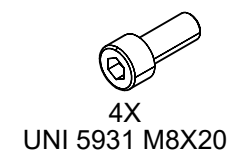
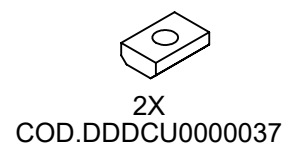
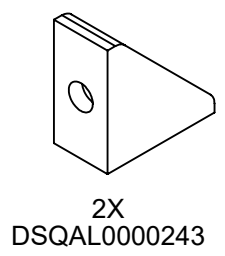
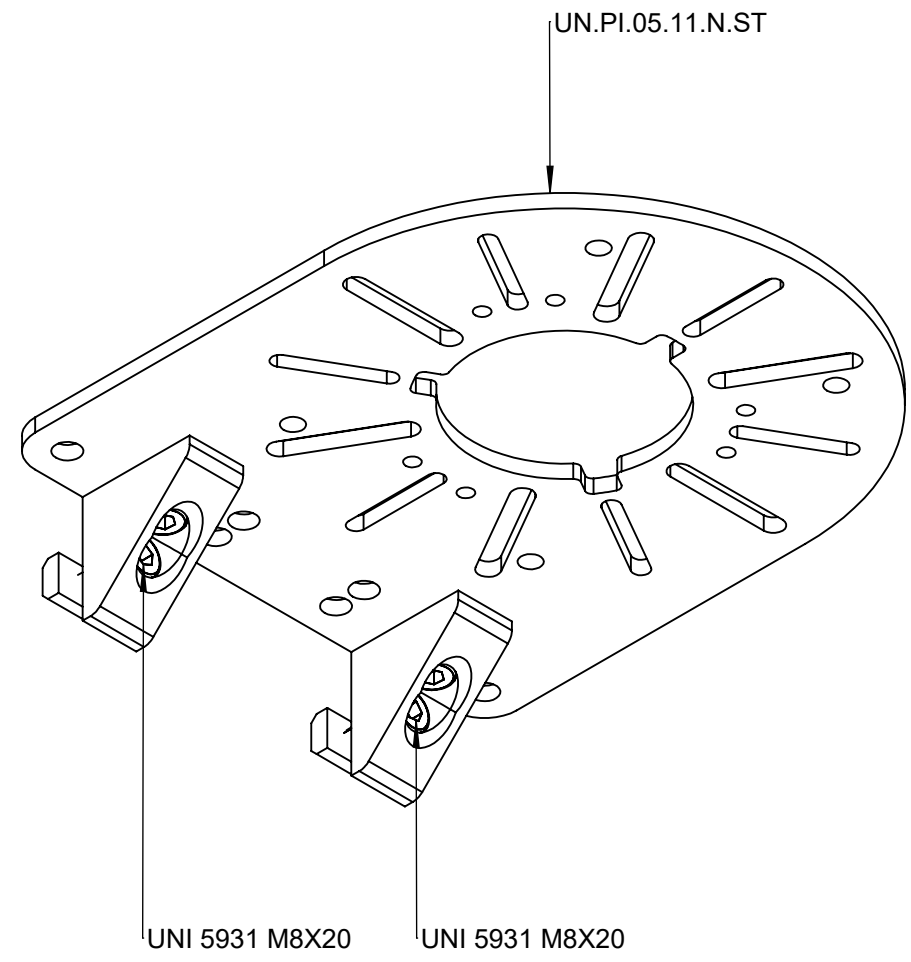
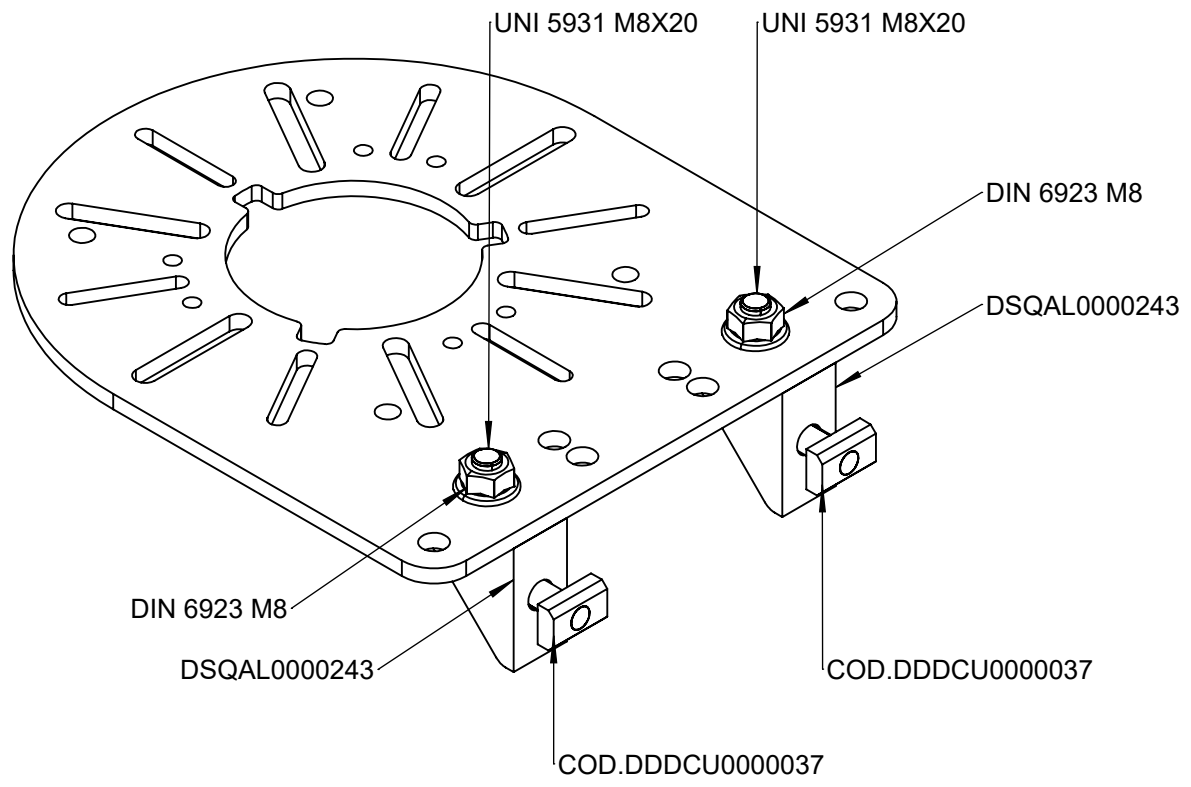

ITA- In questo diagramma potete vedere come si installa a lato

ENG- In this diagram you can see how it is installed on the side

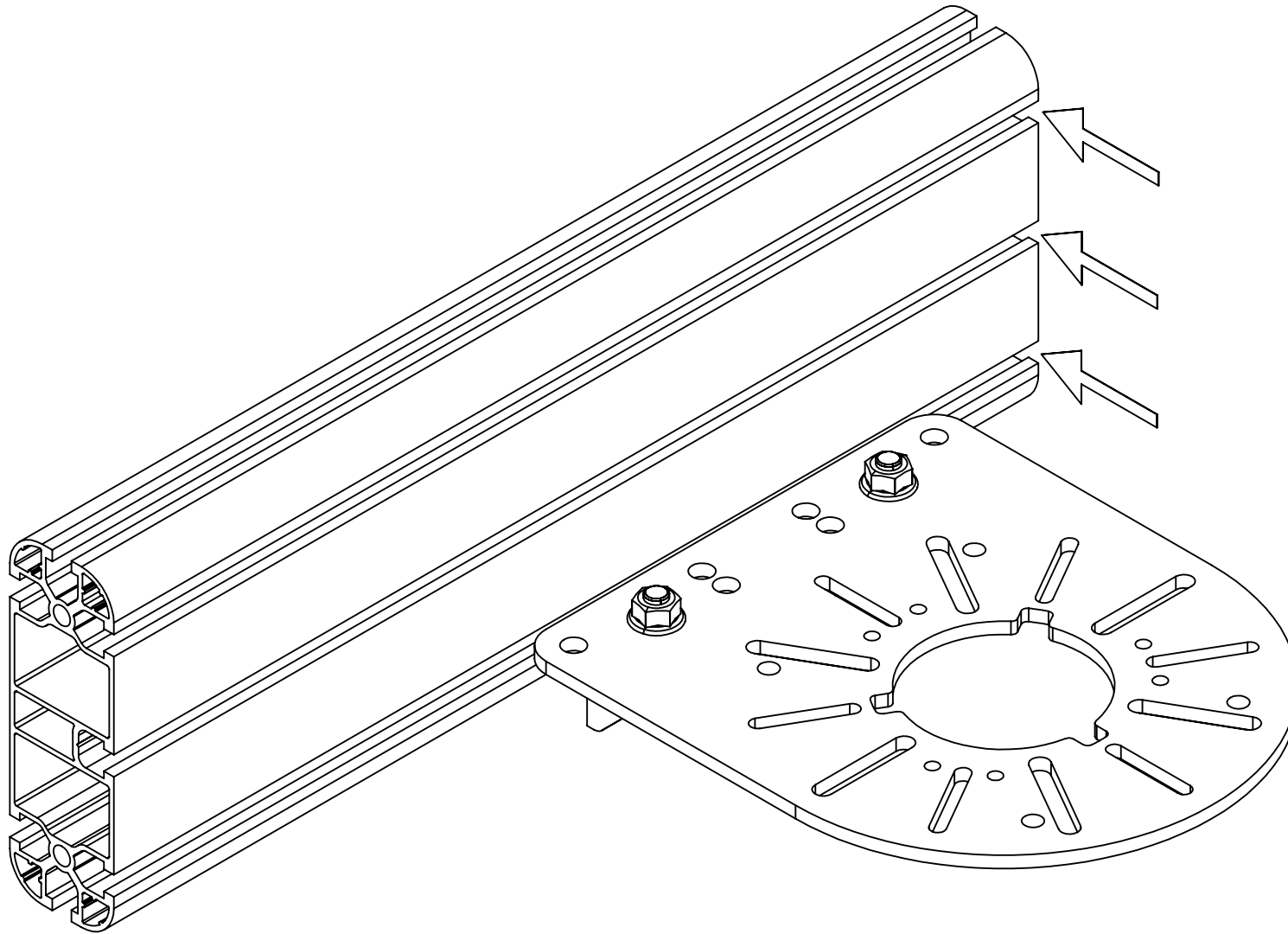

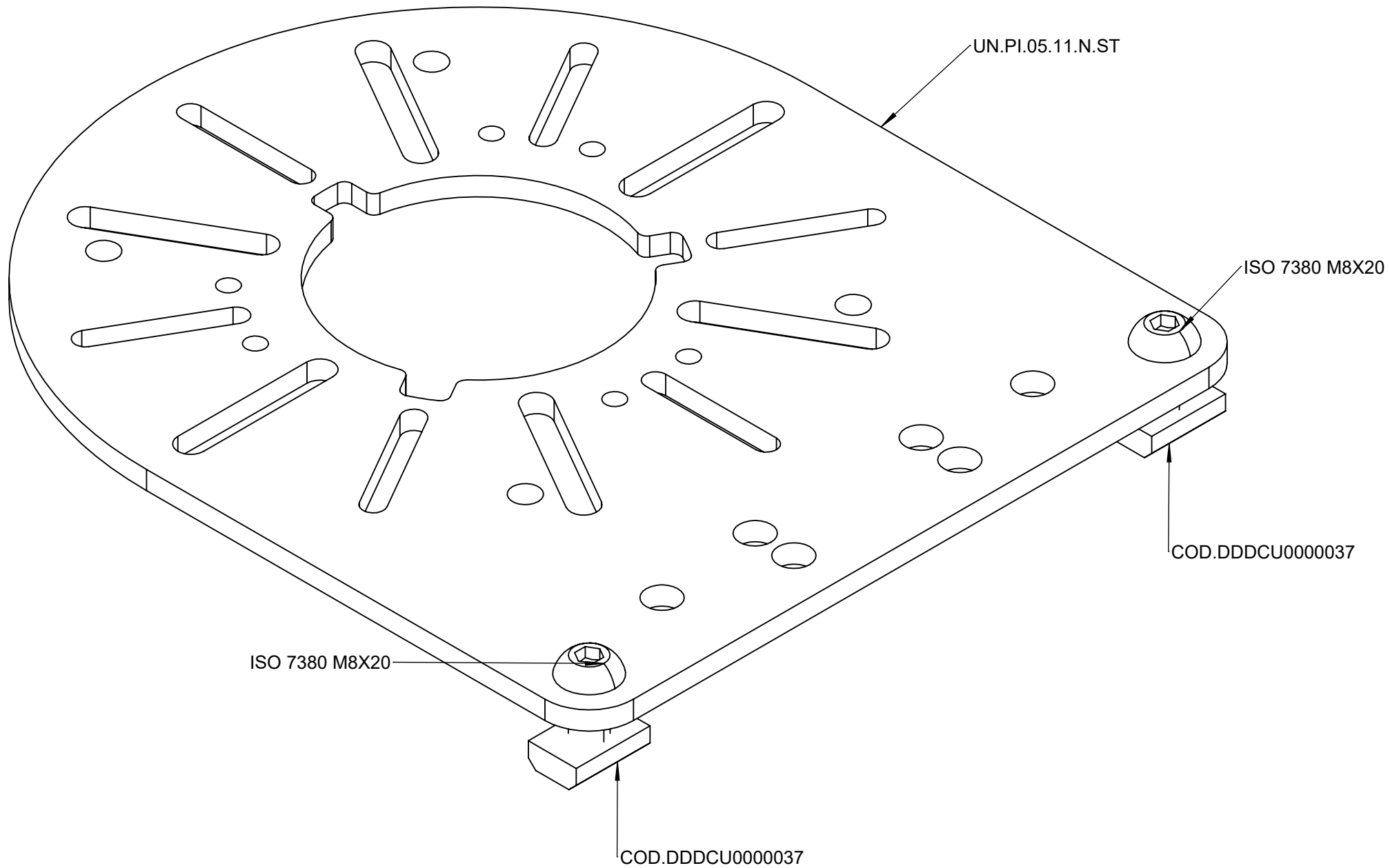

2X  
ISO 7380 M8X20



2X  
COD.DDDCU000037

ITA- In questo diagramma potete vedere come si installa dal lato superiore

ENG- In this diagram you can see how it is installed from the top side

