

MANUALE DI ISTRUZIONI - INSTRUCTION MANUAL

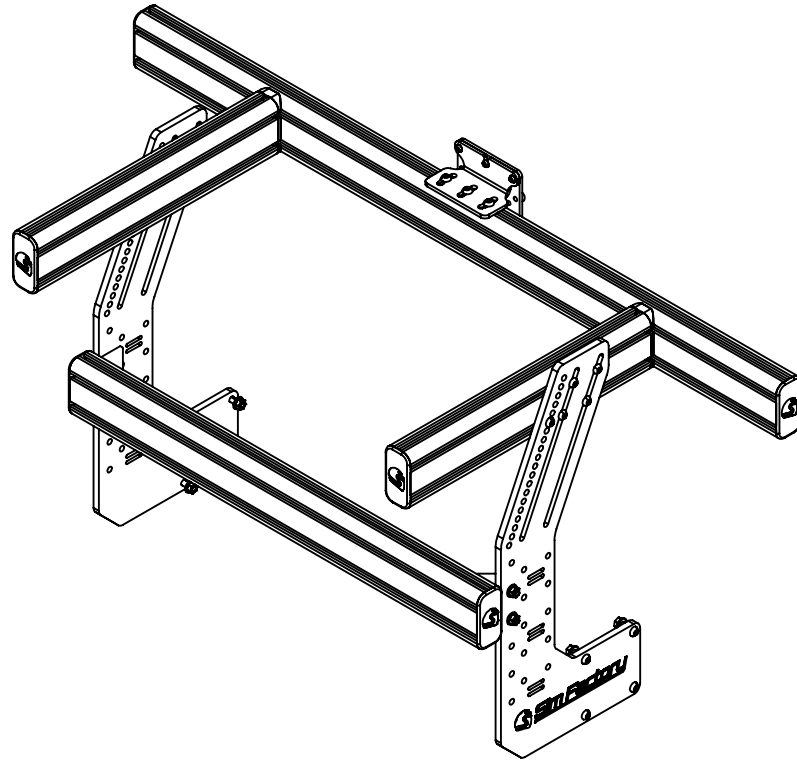

COCKPIT-MOUNTED MONITOR

PRIMA DI PARTIRE:

ITA- Grazie per aver acquistato questo prodotto Sim Factory!
Nelle pagine seguenti troverete istruzioni dettagliate sull'assemblaggio.
Ciò richiede degli strumenti semplici e un po' del vostro tempo.

A seconda del prodotto scelto l'assemblaggio può richiedere da qualche minuto a molte ore, ma adorerete ogni minuto speso per dar forma al vostro prodotto Sim Factory.

BEFORE YOU START:

ENG- Thank you for purchasing this Sim Factory product!
On the following pages, you will find detailed instructions on assembly.
This requires only a set of simple tools and some of your time.

Depending on the product chosen assembly can take from a few minutes to many hours, but you will love every minute spent on shaping your Sim Factory product.

ITA- Strumenti necessari:

ENG- Tools needed:

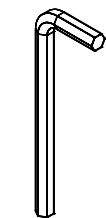

4mm
5mm
6mm

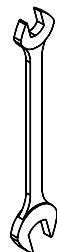

13mm
17mm

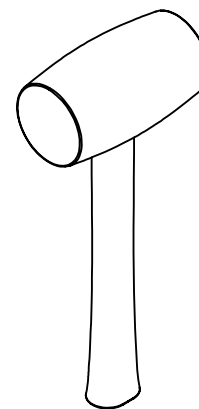

martello in gomma
rubber hammer

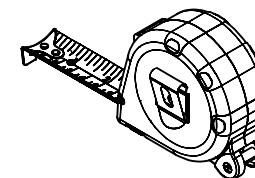

Inserimento cursori:

ITA- In questo diagramma potete vedere come inserire un cursore direttamente nella cava. Potete anche usare una delle chiavi esagonali più piccole per aiutarvi a muovere il cursore in posizione.

Inserting Slot-Nuts:

ENG- In this diagram, you can see how to insert a Slot-Nut directly into the slot from the side. You can also use one of your smaller Hex wrenches to help wiggle the Slot-Nut in place.

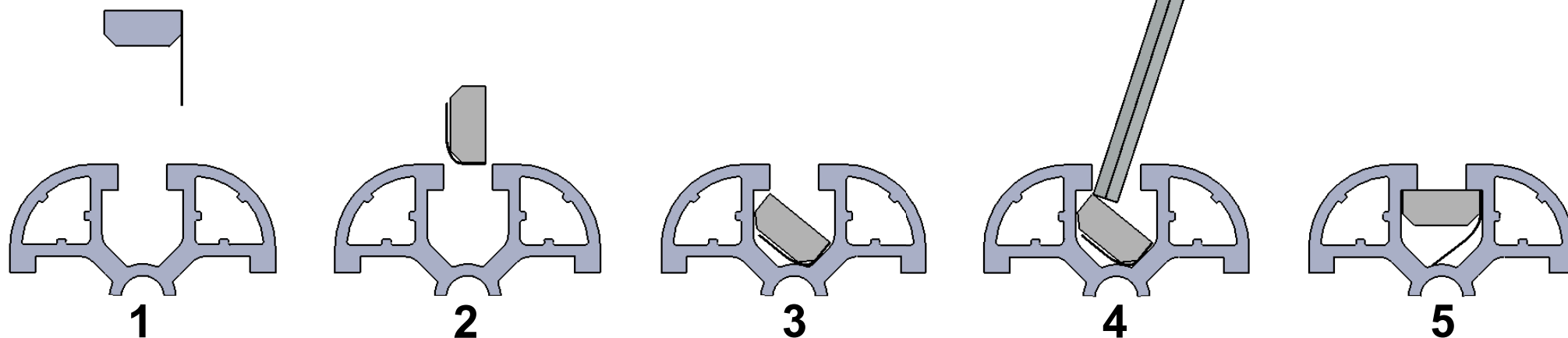
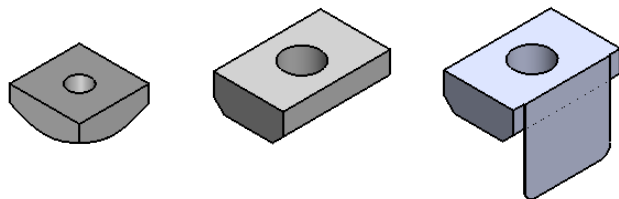

Foro passaggio chiave:

ITA- In questo diagramma potete vedere come eseguire il fissaggio correttamente.

Hex wrenches passage hole:

ENG- In this diagram, you can see how to fixing correctly.

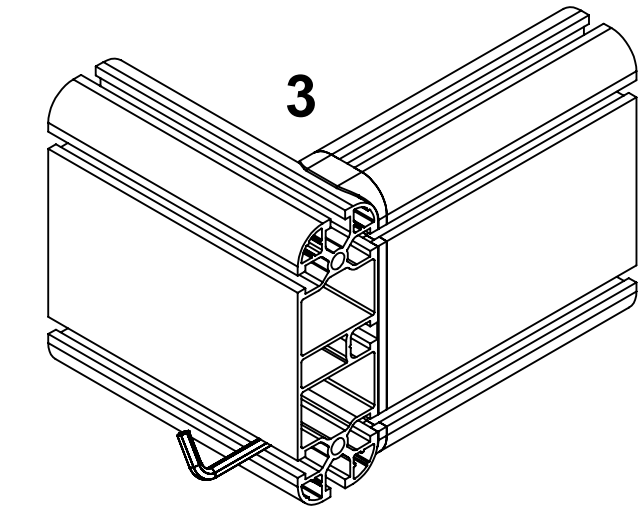
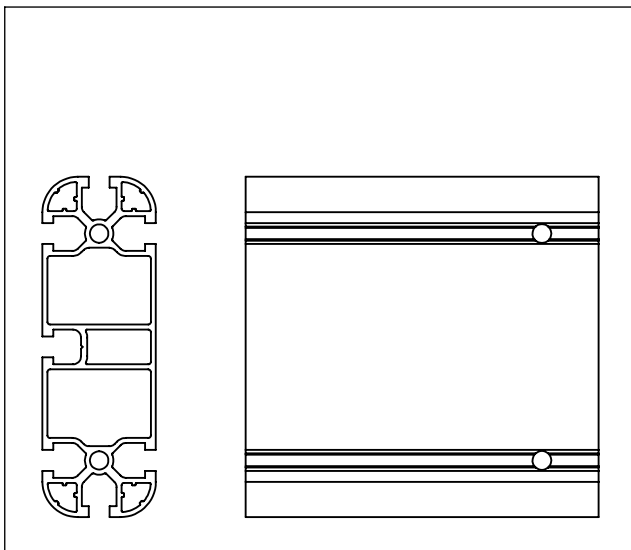
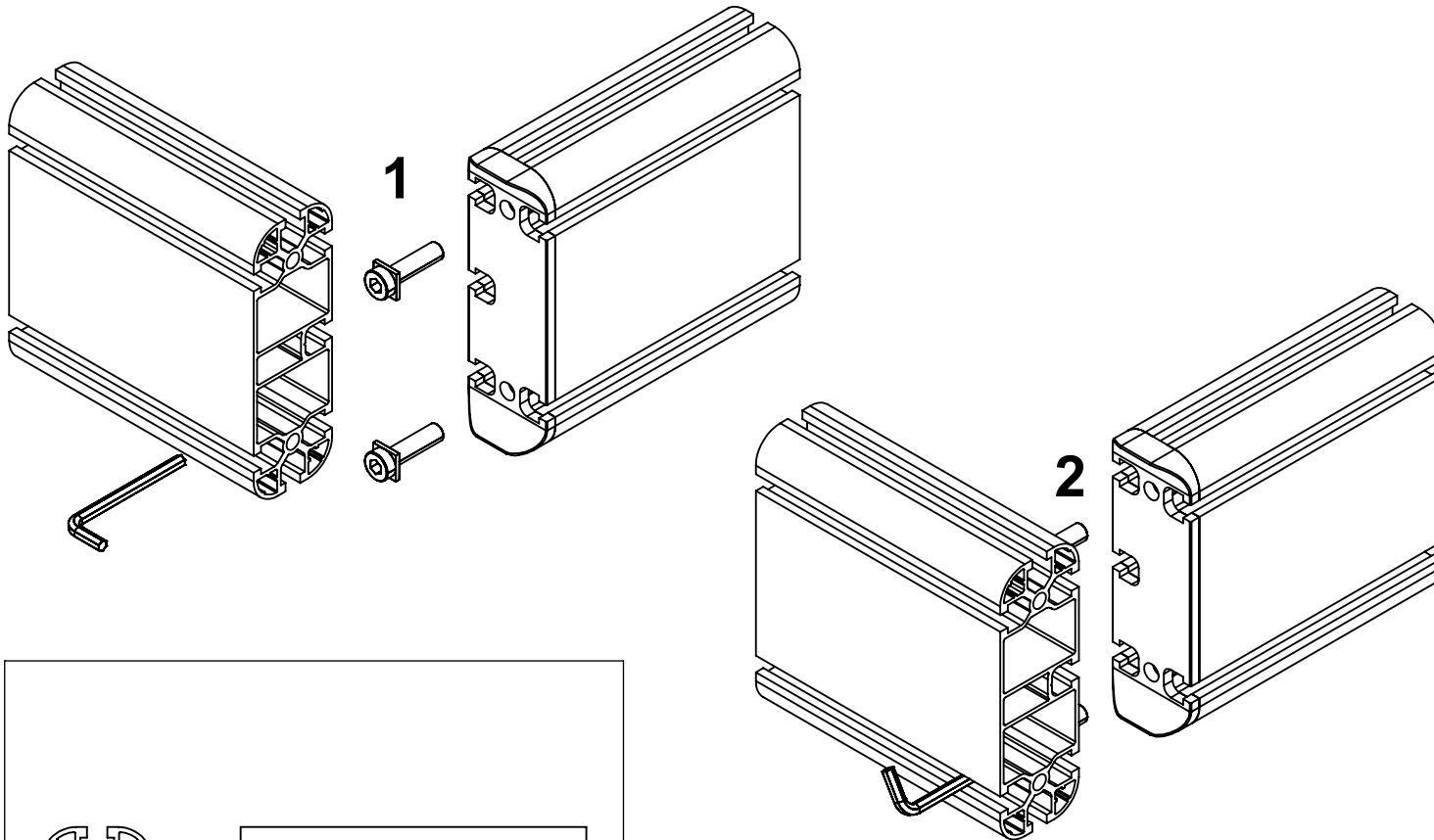

ITA- Vite a testa ribassata
ENG- Low head screw

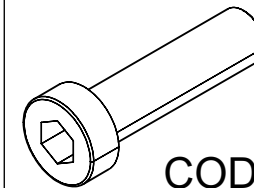

COD.CVITB0000023

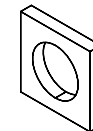

COD.CROY0000013

Foro passaggio chiave:

ITA- In questo diagramma potete vedere un altro modo per eseguire il fissaggio.

Hex wrenches passage hole:

ENG- In this diagram, you can see another way to do the fixing.

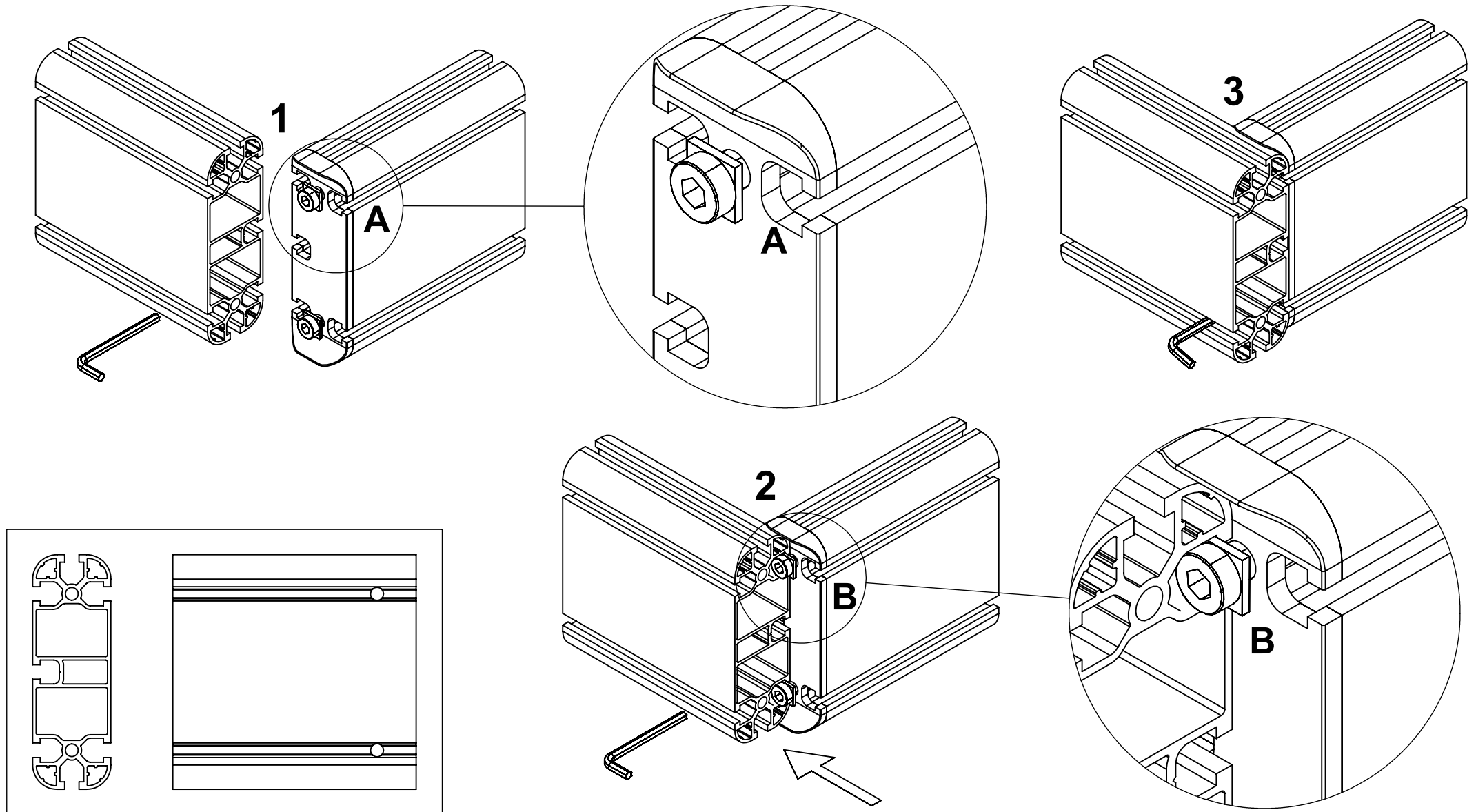



Inserimento tappi e giunti:

ITA- In questo diagramma potete vedere come inserire un tappo o un giunto. Potete anche usare il martello in gomma per incastrare il tappo o il giunto. Colpite la parte piatta del giunto, non occorre molta forza.

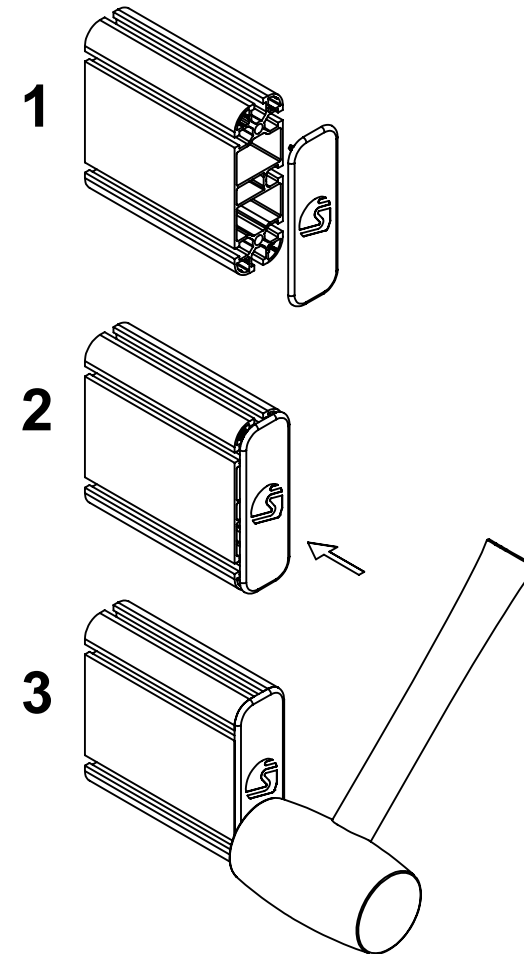
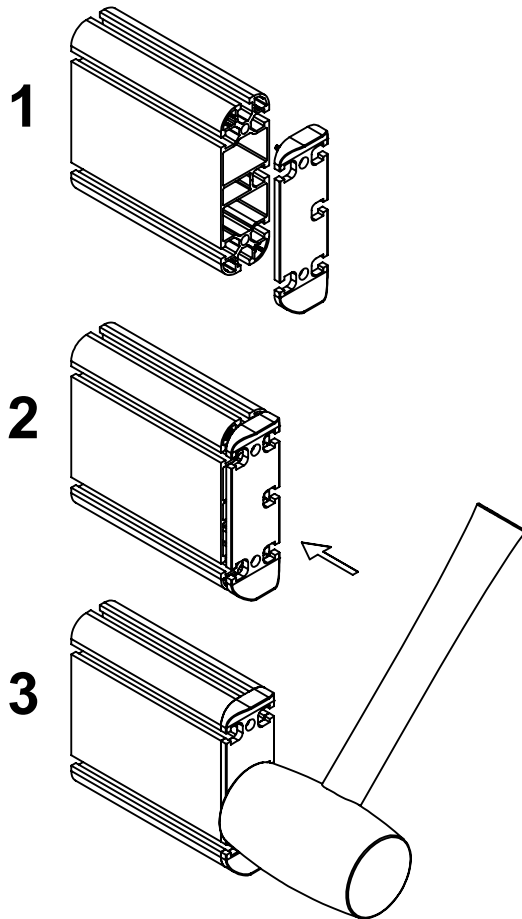

Inserting caps and joints:

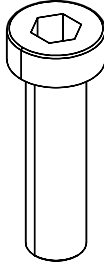
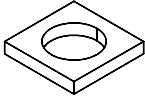
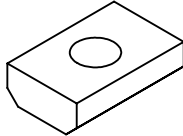
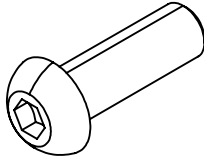
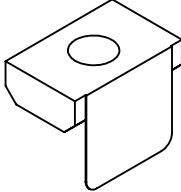
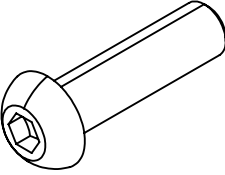
ENG- In this diagram, you can see how to insert a cap or joint. You can also use the rubber hammer to tap in the cap or joint. Hit the flat part of the joint, it doesn't take much force.

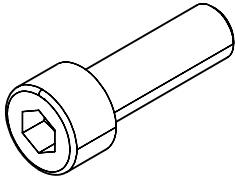
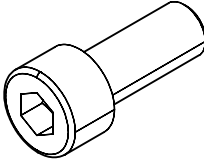
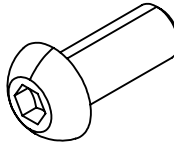
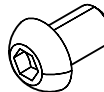

<p>DIN 7984 M8X30 COD.CVITB0000023 4 PZ</p> <p>SA.01.USI.01</p>	<p>13X13X2 COD.CROY0000013 4 PZ</p> <p>SA.01.USI.01</p>	<p>M8 13X20X6 COD.DDDCU0000037 18 PZ</p> <p>SA.01.USI.01</p>	<p>ISO 7380 M8X25 18 PZ</p> <p>SA.01.USI.01</p>	<p>M8 13X20X6 COD.DDDCU0000038 8 PZ</p> <p>SA.01.USI.01</p>	<p>ISO 7380 M8X30 8 PZ</p> <p>SA.01.USI.01</p>
					
<p>DIN 6923 M8 12 PZ</p> <p>SA.02.USI.01</p>	<p>UNI 5931 M8X25 4 PZ</p> <p>SA.02.USI.01</p>	<p>UNI 5931 M8X20 4 PZ</p> <p>SA.02.USI.01</p>	<p>ISO 7380 M8X20 3 PZ</p> <p>SA.02.USI.01</p>	<p>ISO 7380 M6X10 3 PZ</p> <p>SA.02.USI.01</p>	
					

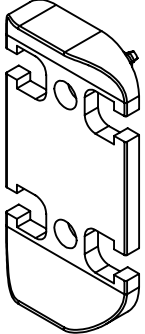
ITA- COSA C'È NELLA SCATOLA
ENG- WHAT'S IN THE BOX

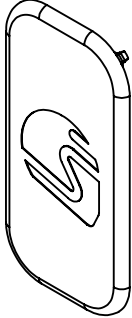
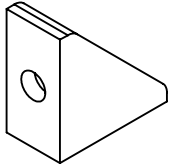
<p>GO.14.45.090.N 2 PZ</p> <p>SA.03.USI.01</p>	<p>TUA00300200425 4 PZ</p> <p>SA.03.USI.01</p>	<p>TI.15.45.090.N 6 PZ</p> <p>SA.03.USI.01</p>	<p>DSQAL0000243 4 PZ</p> <p>SA.04.USI.01</p>		
					

ITA- COSA C'È NELLA SCATOLA
ENG- WHAT'S IN THE BOX

DIM: 150 X 25 X H 25
WEIGHT: 15 KG
COD: KI.USI.01.N

PR.090.N.L450.FI	2PZ
PR.090.N.L762.FO	1PZ
PR.090.N.L1200.FO	1PZ
UN.PI.05.06.N.TF	1PZ
UN.PI.05.07.N.TP	1PZ
UN.PI.10.11.N.ST	2PZ
SA.01.USI.01 :	
COD.CVITB0000023	4PZ
COD.CROY0000013	4PZ
COD.DDDCU0000037	18PZ
ISO 7380 M8X25	18PZ
COD.DDDCU0000038	8PZ
ISO 7380 M8X30	8PZ
SA.02.USI.01 :	
DIN 6923 M8	12PZ
UNI 5931 M8X25	4PZ
UNI 5931 M8X20	4PZ
ISO 7380 M8X20	3PZ
ISO 7380 M6X10	3PZ
SA.03.USI.01 :	
TI.15.45.090.N	6PZ
GO.14.45.090.N	2PZ
TUA00300200425	4PZ
SA.04.USI.01 :	
DSQAL0000243	4PZ

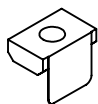
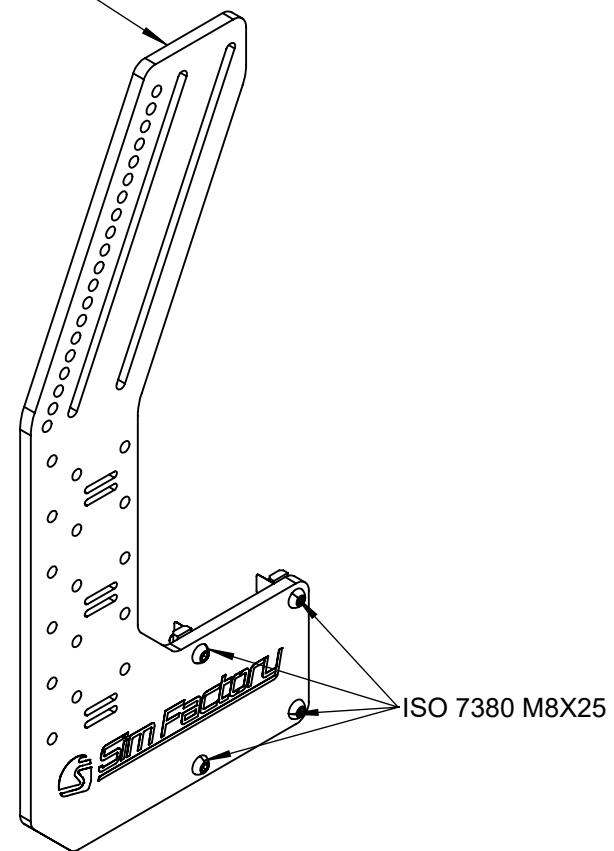
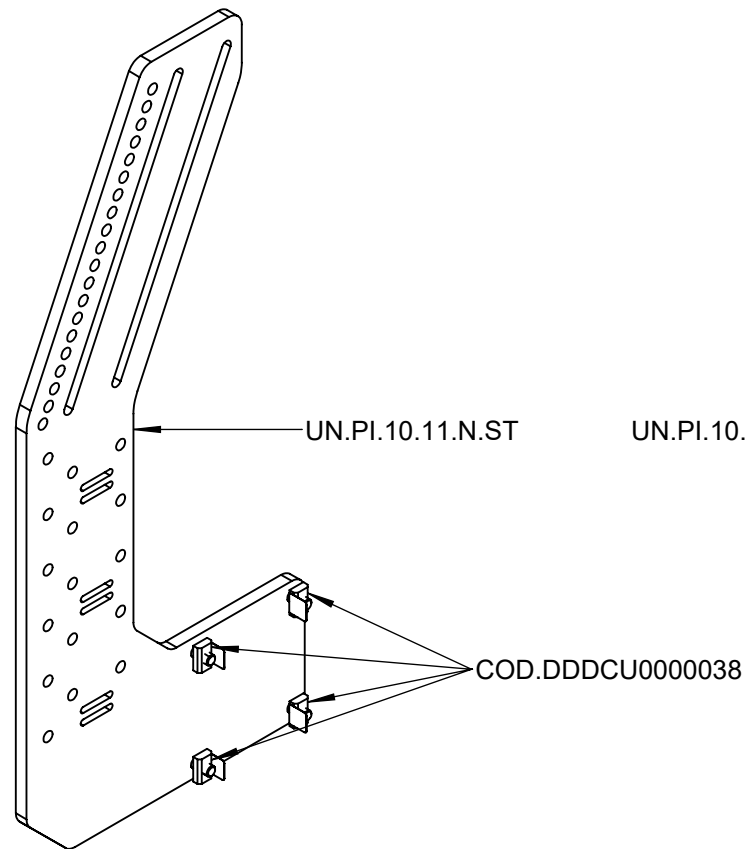

8X

COD.DDDCU0000038

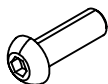

8X

ISO 7380 M8X25

ITA- In questo diagramma potete vedere come installare COCKPIT MOUNTED MONITOR su COMPETIZIONE.

ENG- In this diagram you can see how to install COCKPIT MOUNTED MONITOR on COMPETIZIONE.

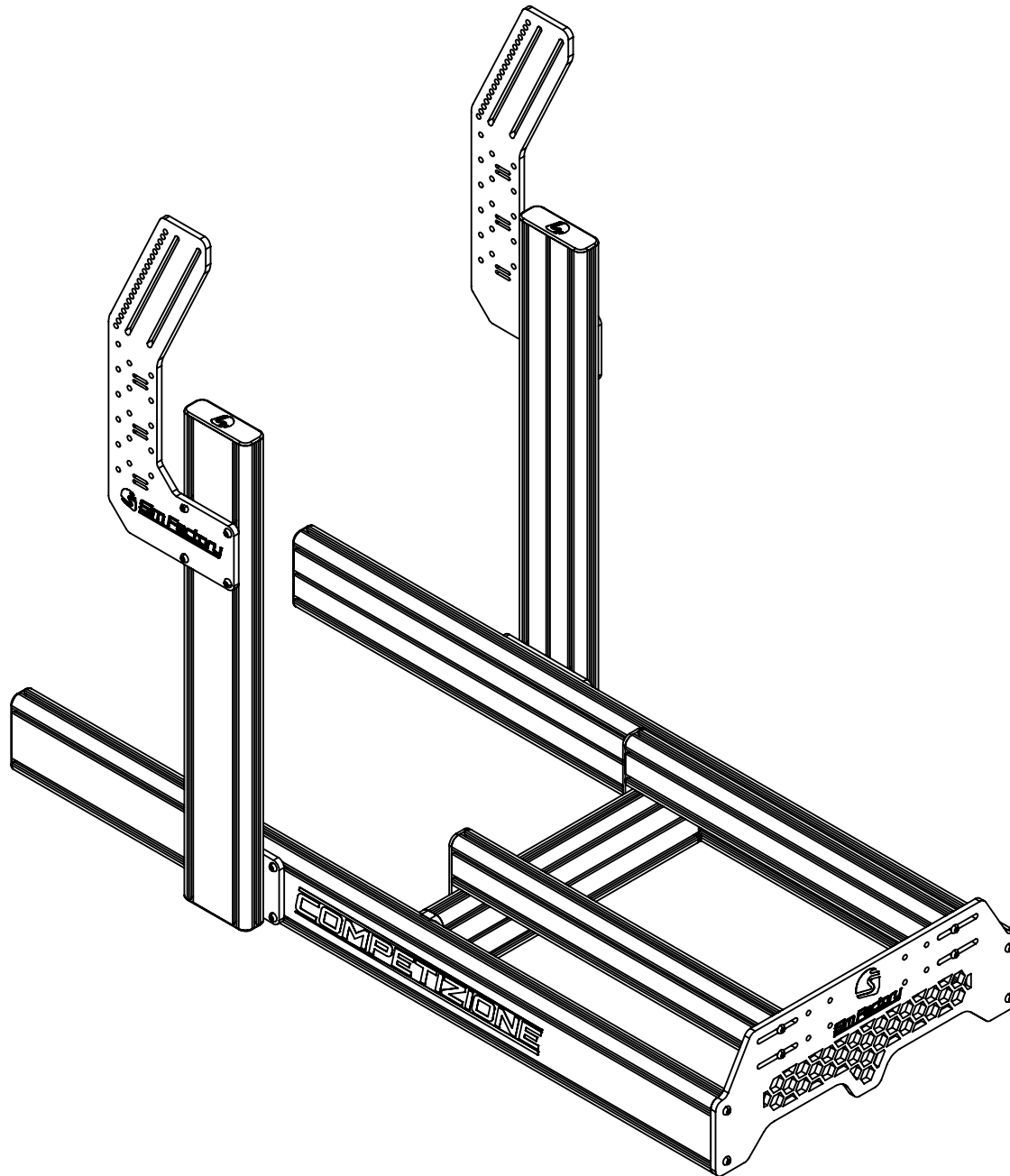

GO.14.45.090.N

PR.090.N.L450.FI

GO.14.45.090.N

COD.DDDCU0000037

PR.090.N.L1200.FO

697mm

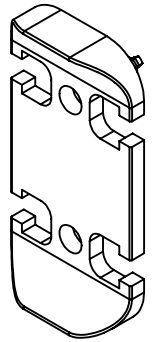
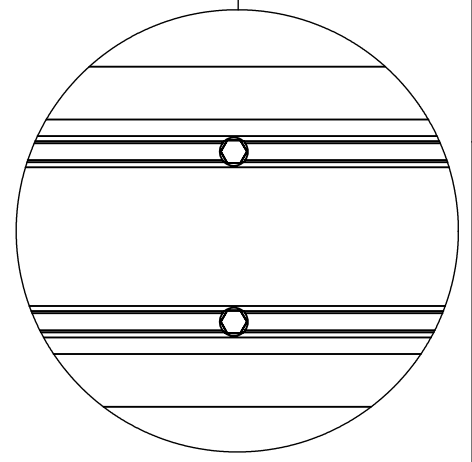
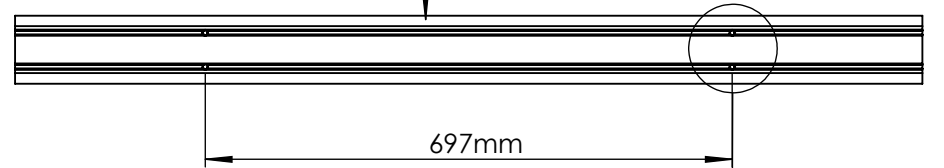
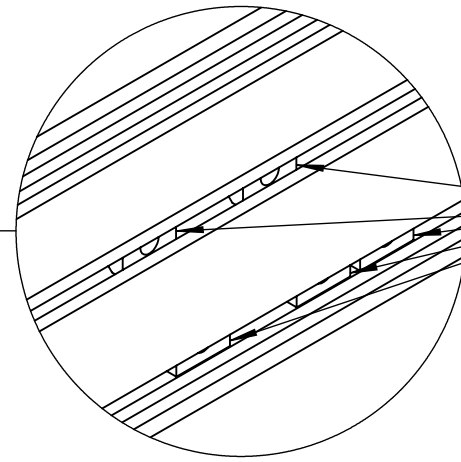
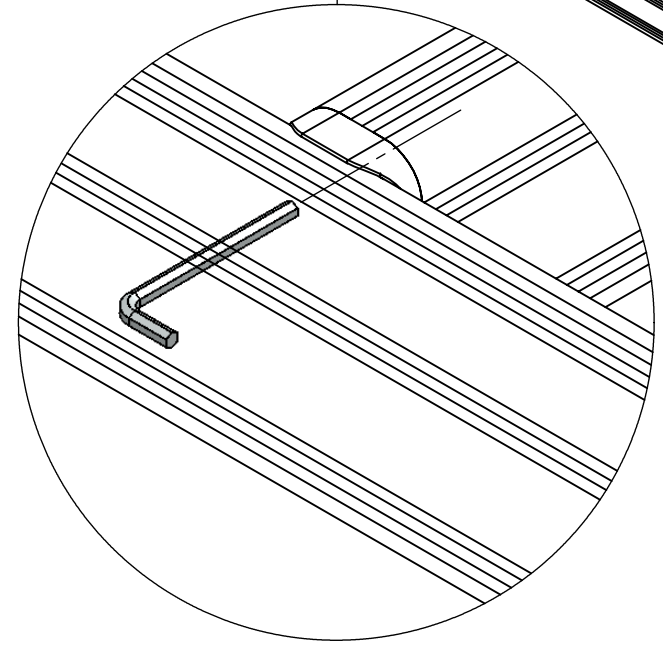

2X

GO.14.45.090.N



4X

COD.CROY0000013

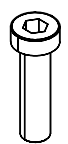

4X

COD.CVITB0000023

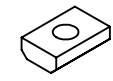

10X

COD.DDDCU0000037

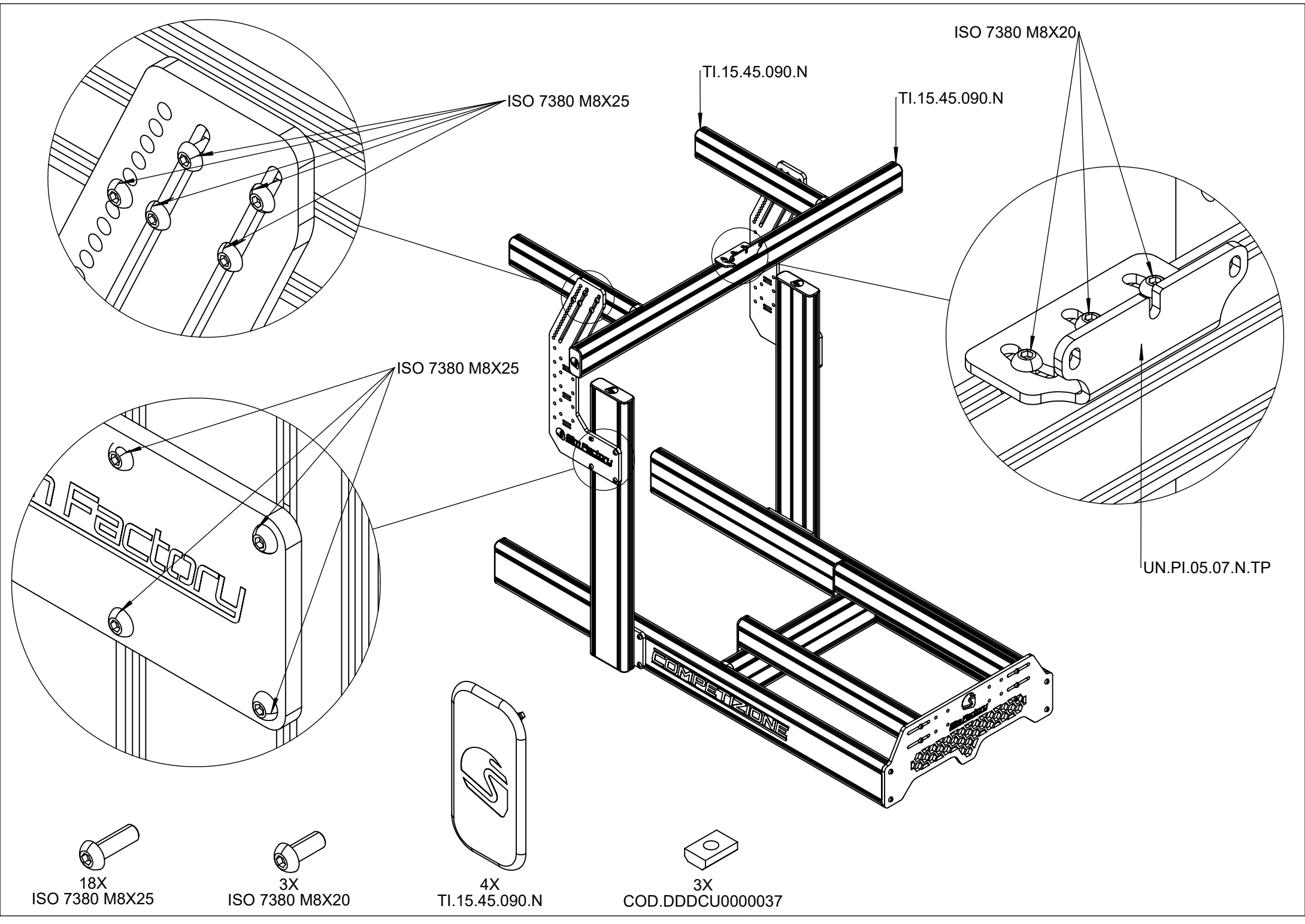

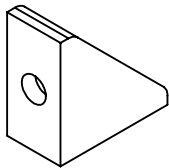
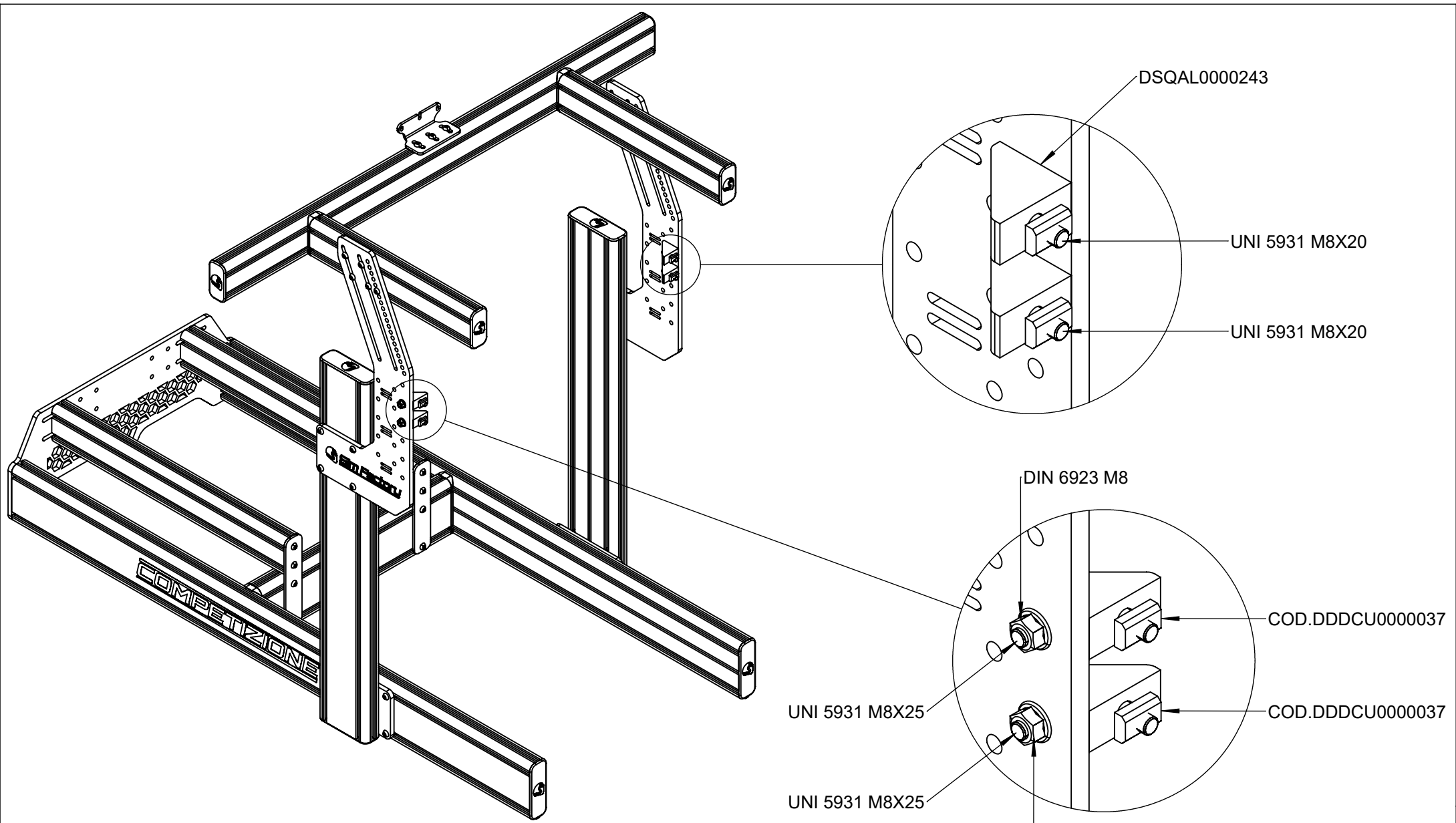

4X
DSQAL0000243



4X
DIN 6923 M8



4X
COD.DDDCU0000037

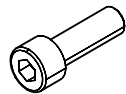

4X
UNI 5931 M8X25

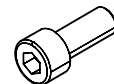

4X
UNI 5931 M8X20

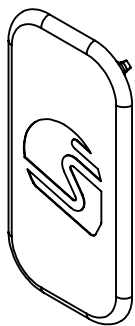
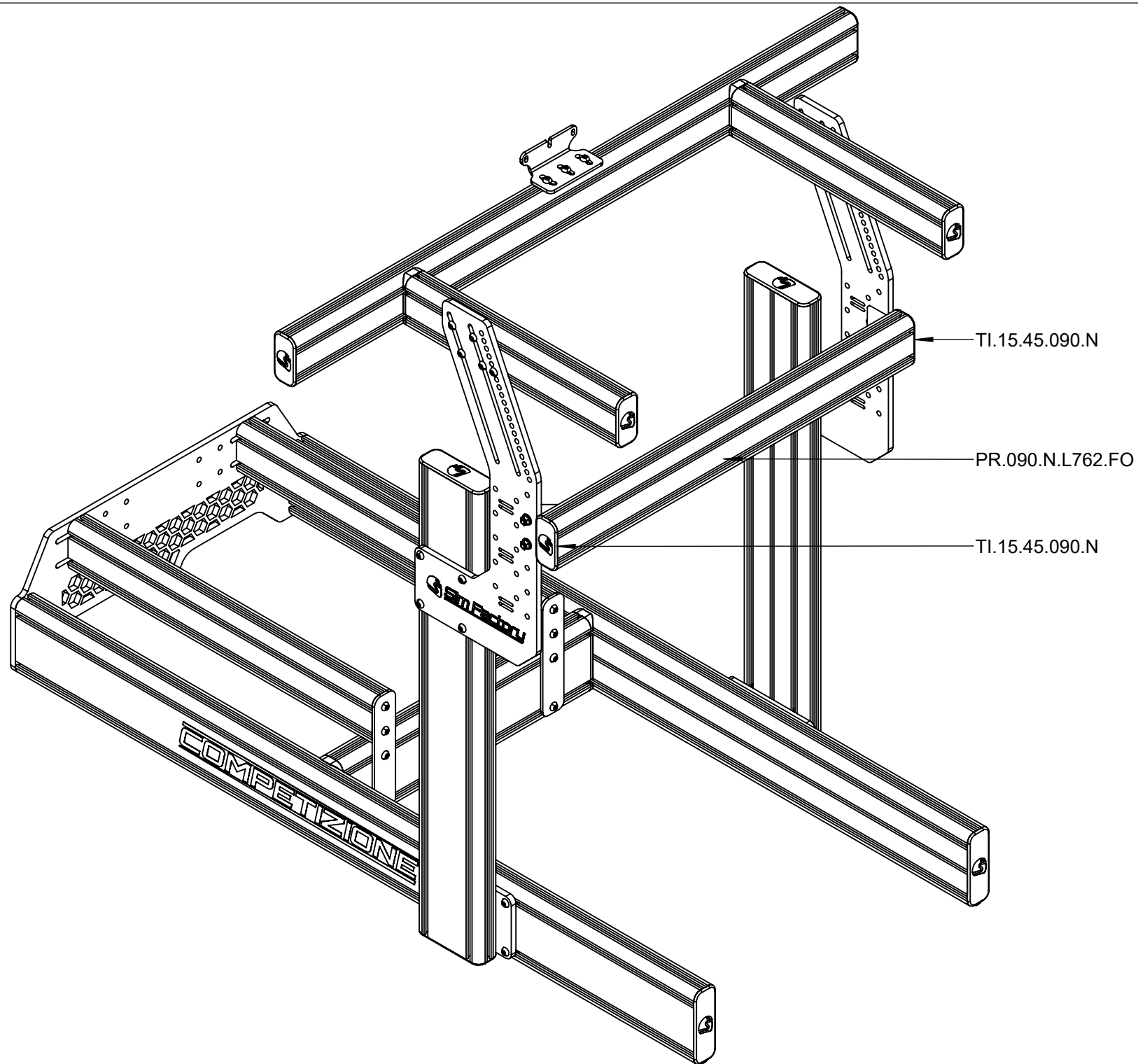

2X
TI.15.45.090.N

ITA- In questo diagramma potete vedere come installare i monitors correttamente.

ENG- In this diagram you can see how to install the monitors correctly.

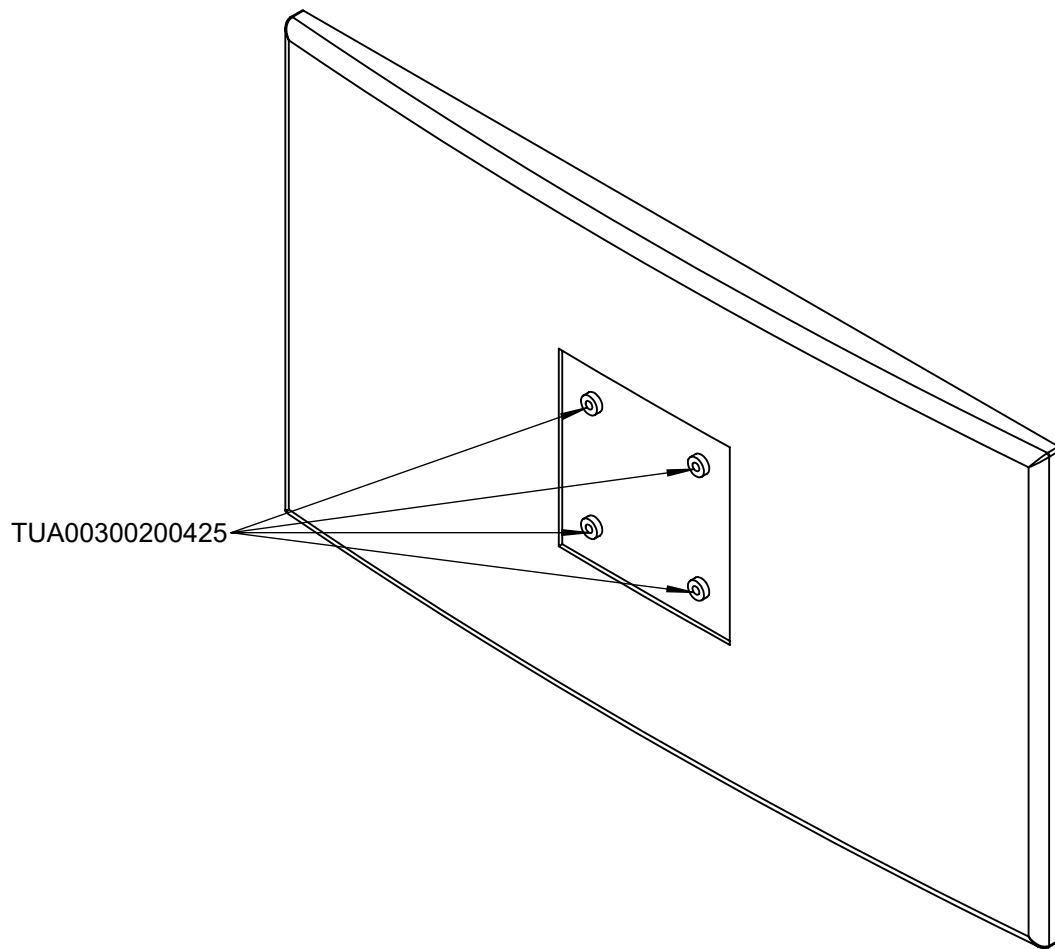
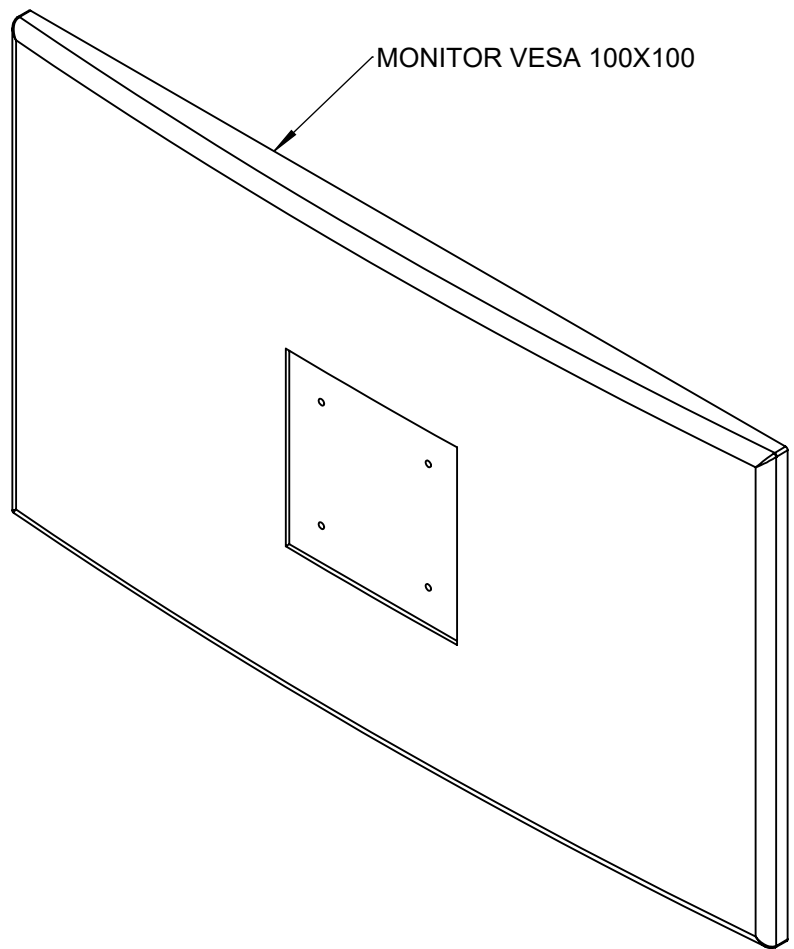

4X

TUA00300200425

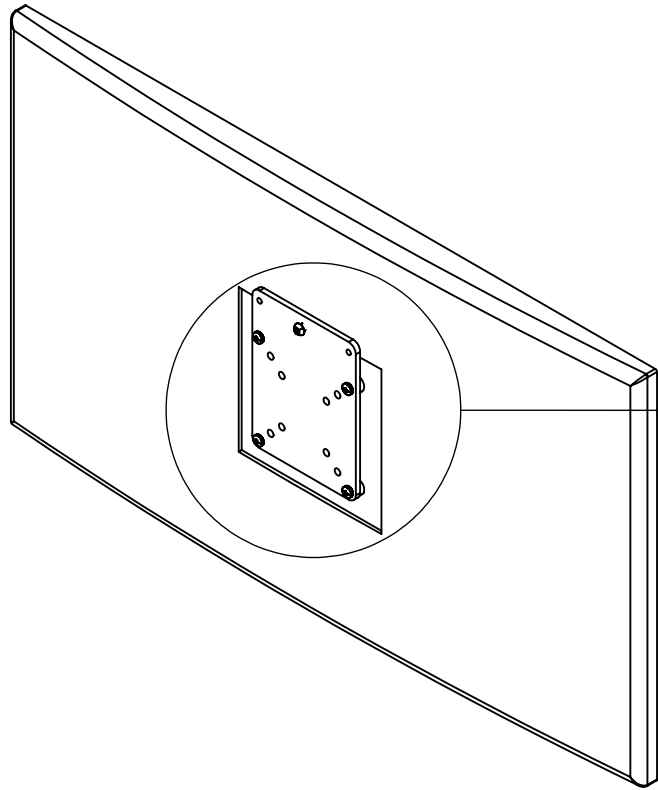

ISO 7380 M6X10

ITA- Viti installazione monitor non incluse.

ENG- Monitor installation screws not included.

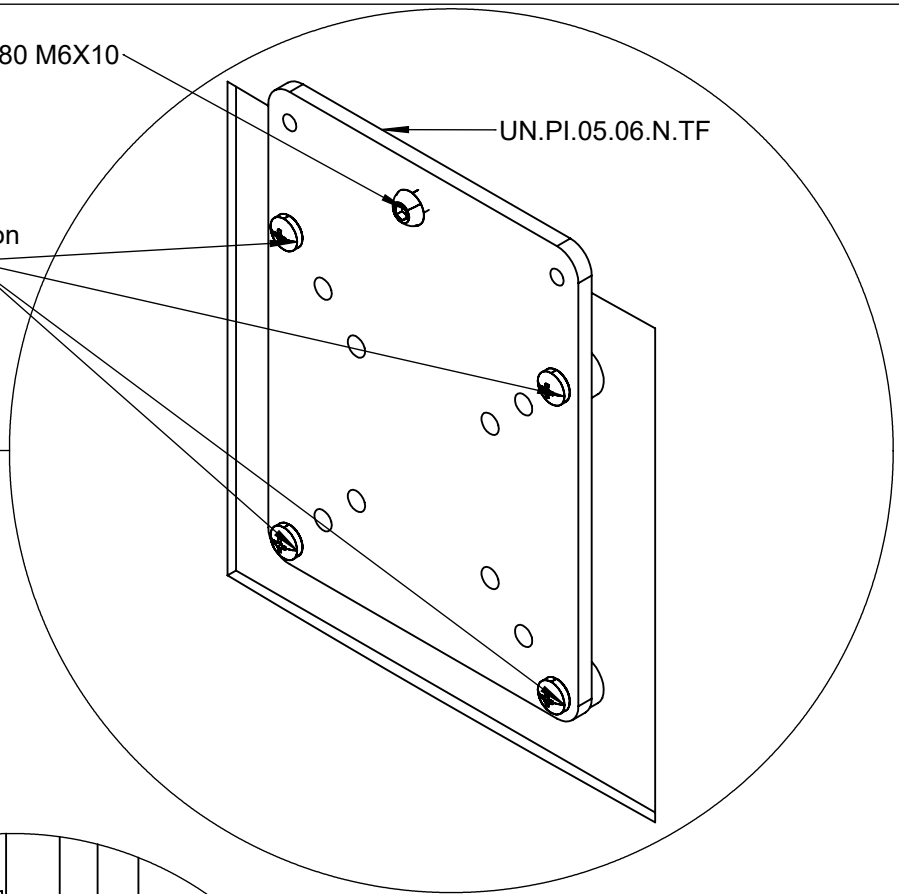

UN.PI.05.06.N.TF

ISO 7380 M6X10

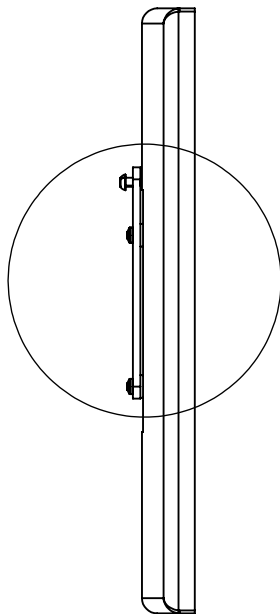

UN.PI.05.06.N.TF

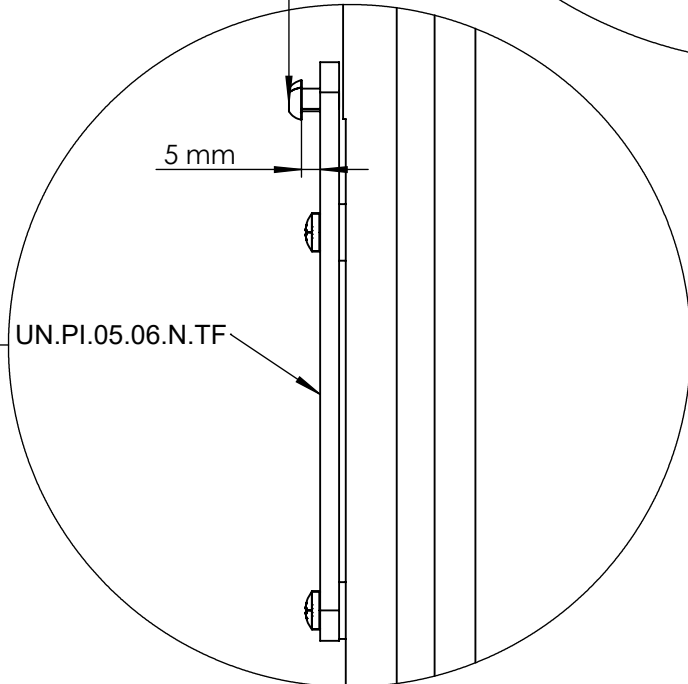

5 mm



1X
ISO 7380 M6X10

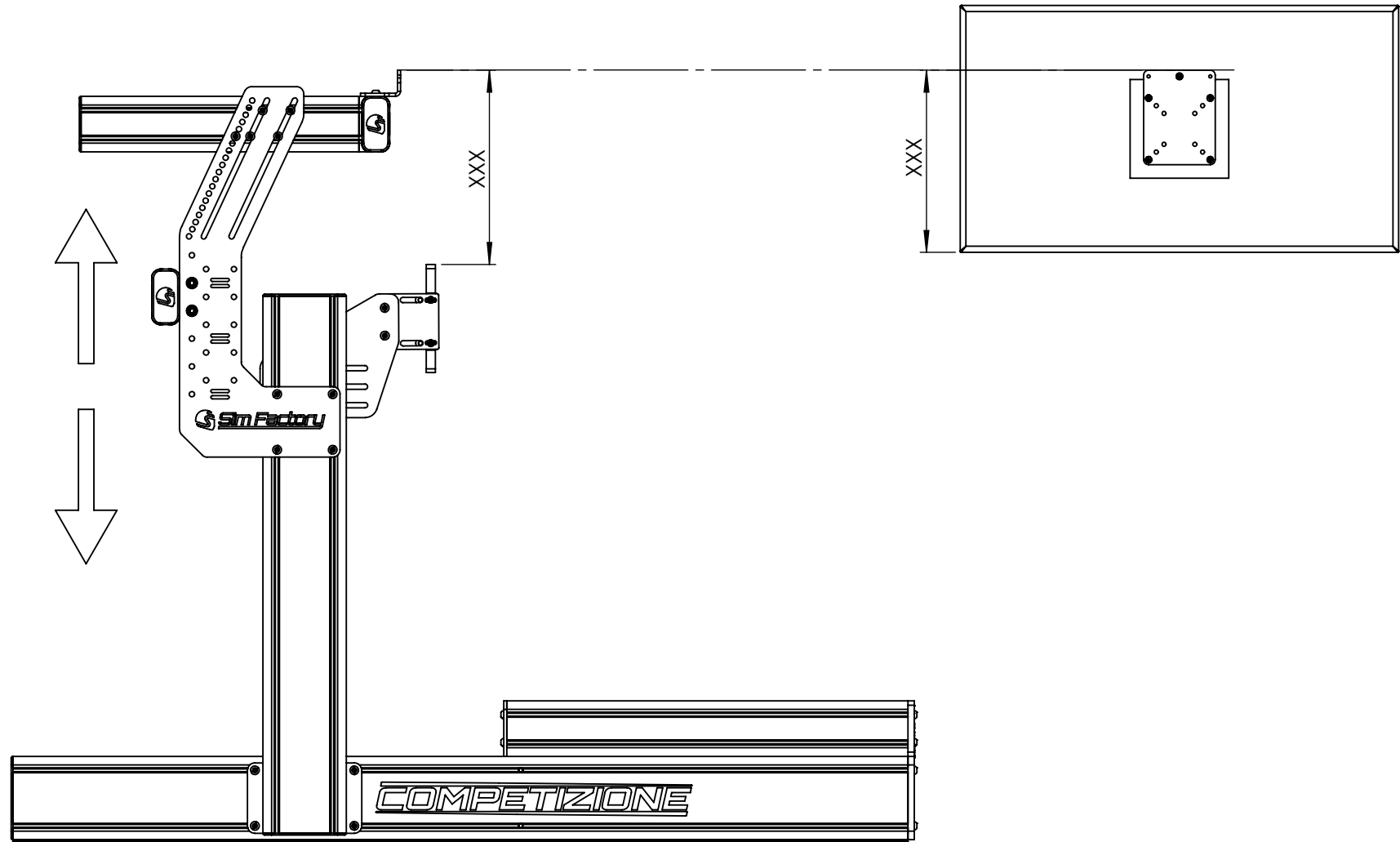

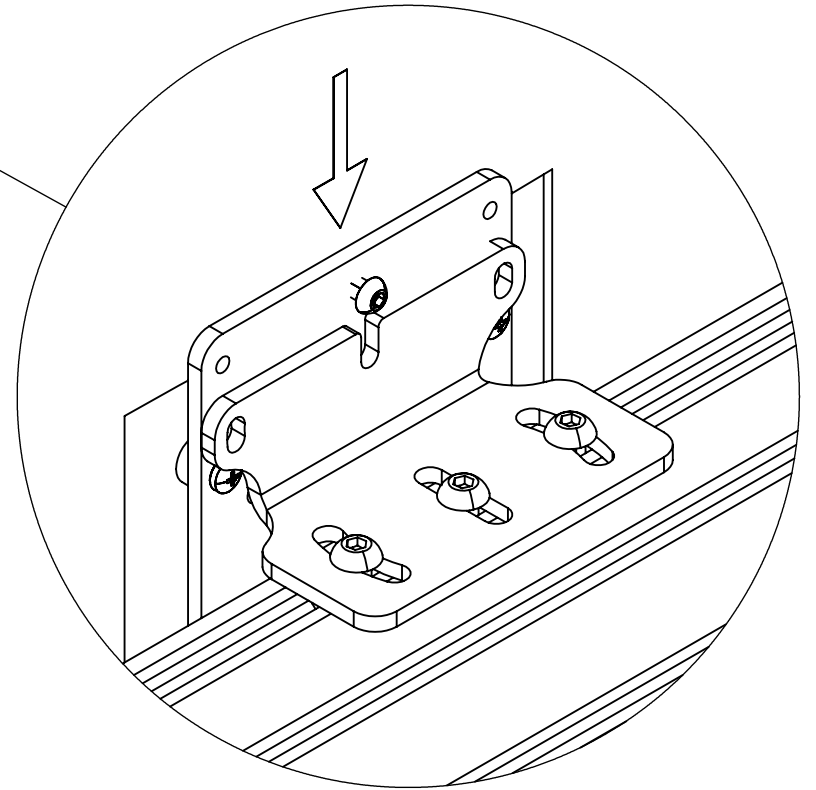
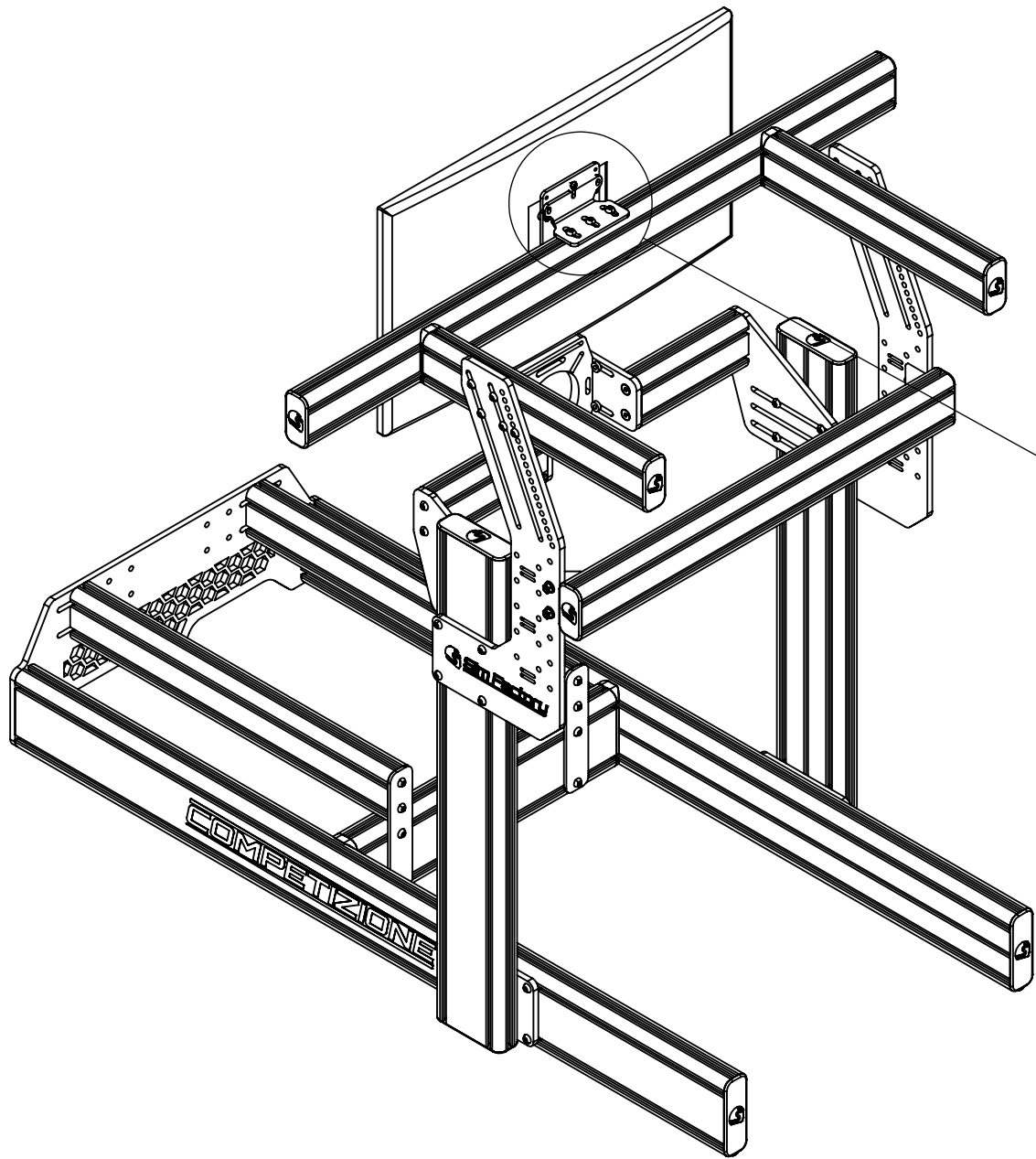

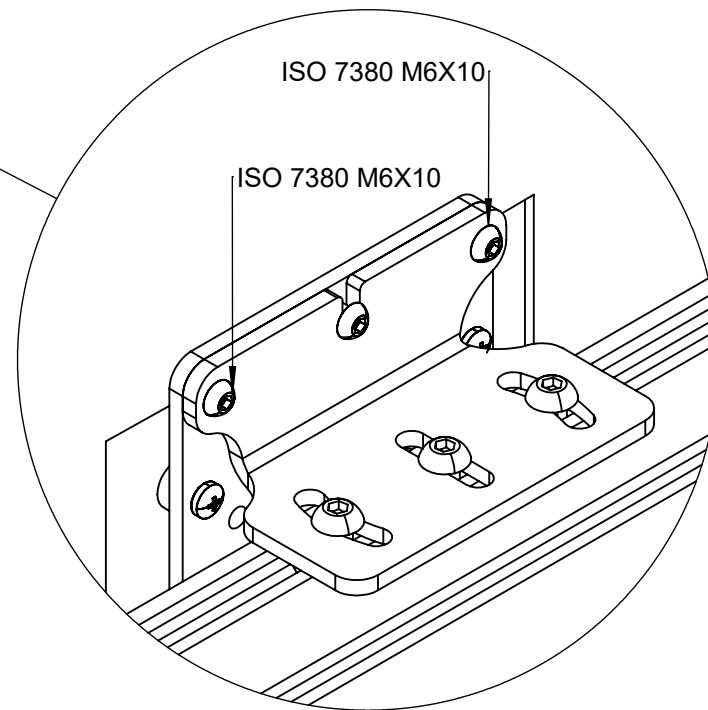
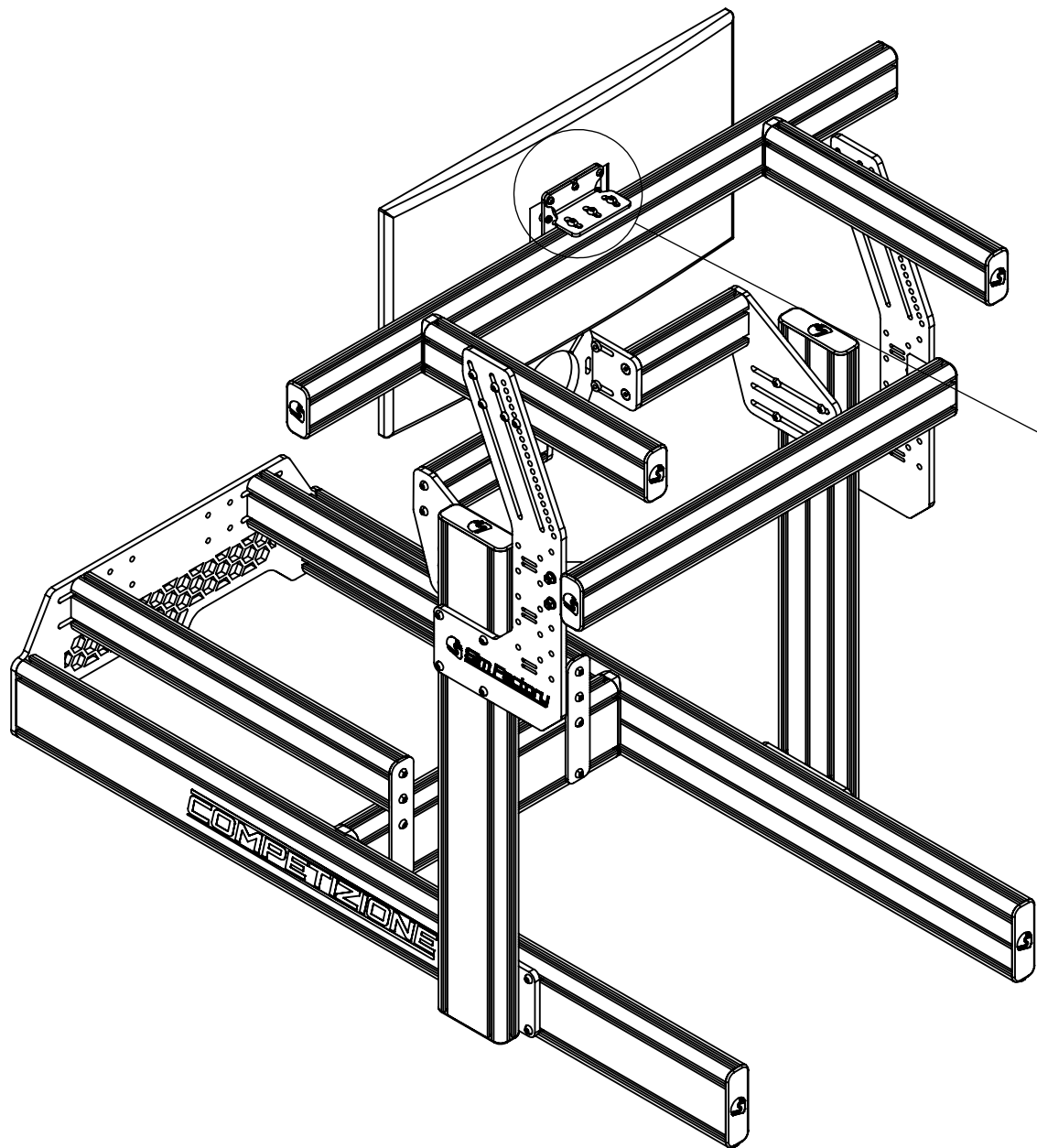

2X
ISO 7380 M6X10