

MANUALE DI ISTRUZIONI - INSTRUCTION MANUAL

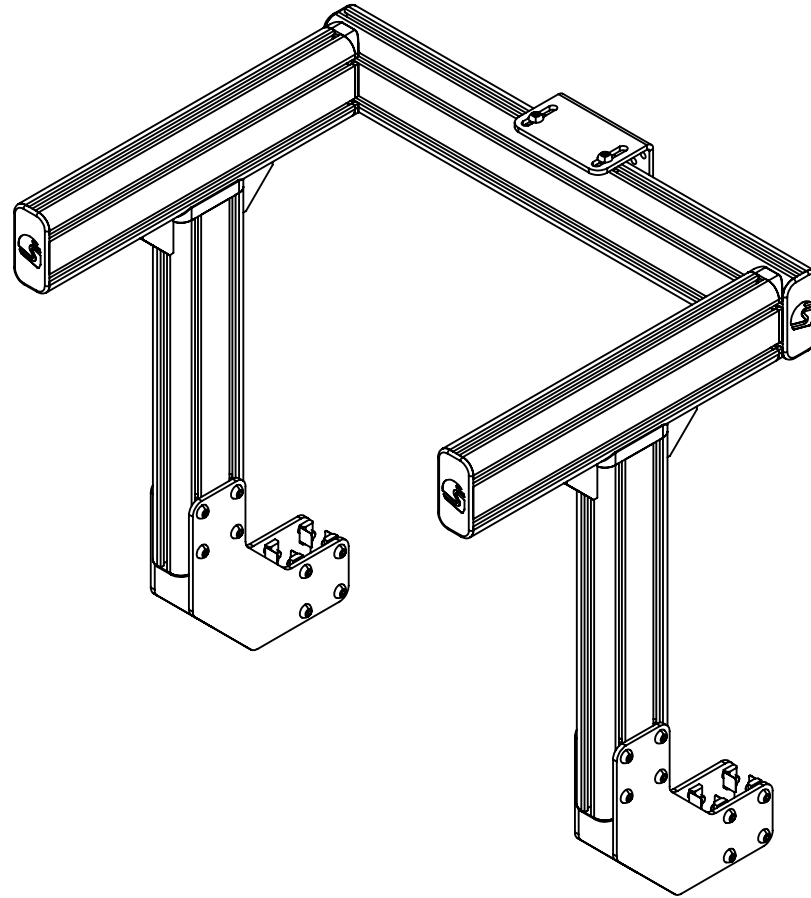

PERFORMANTE COCKPIT MOUNTED MONITOR

PRIMA DI PARTIRE:

ITA- Grazie per aver acquistato questo prodotto Sim Factory!
Nelle pagine seguenti troverete istruzioni dettagliate sull'assemblaggio.
Ciò richiede degli strumenti semplici e un po' del vostro tempo.

A seconda del prodotto scelto l'assemblaggio può richiedere da qualche minuto a molte ore, ma adorerete ogni minuto speso per dar forma al vostro prodotto Sim Factory.

BEFORE YOU START:

ENG- Thank you for purchasing this Sim Factory product!
On the following pages, you will find detailed instructions on assembly.
This requires only a set of simple tools and some of your time.

Depending on the product chosen assembly can take from a few minutes to many hours, but you will love every minute spent on shaping your Sim Factory product.

ITA- Strumenti necessari:

ENG- Tools needed:

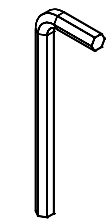

4mm
5mm
6mm

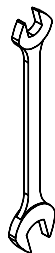

13mm
17mm

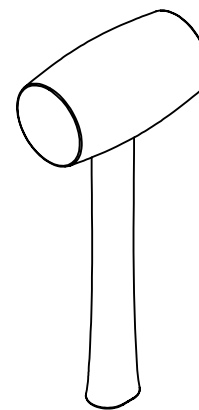

martello in gomma
rubber hammer

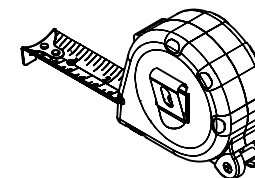

Inserimento cursori:

ITA- In questo diagramma potete vedere come inserire un cursore direttamente nella cava. Potete anche usare una delle chiavi esagonali più piccole per aiutarvi a muovere il cursore in posizione.

Inserting Slot-Nuts:

ENG- In this diagram, you can see how to insert a Slot-Nut directly into the slot from the side. You can also use one of your smaller Hex wrenches to help wiggle the Slot-Nut in place.

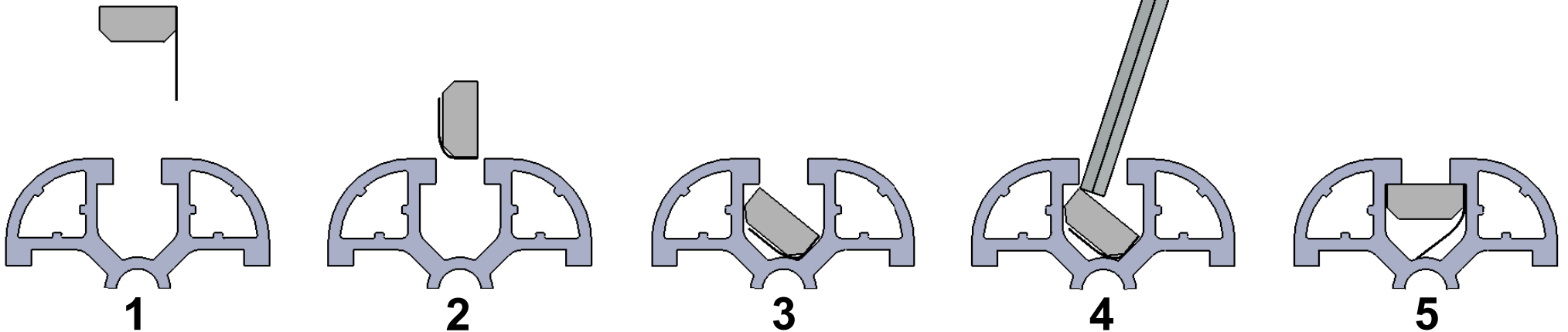
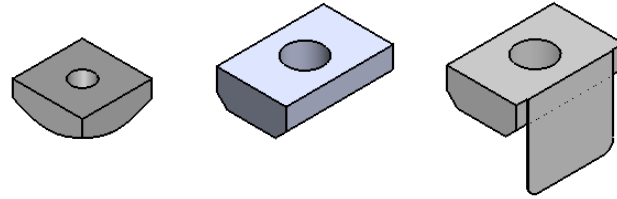

Foro passaggio chiave:

ITA- In questo diagramma potete vedere come eseguire il fissaggio correttamente.

Hex wrenches passage hole:

ENG- In this diagram, you can see how to fixing correctly.

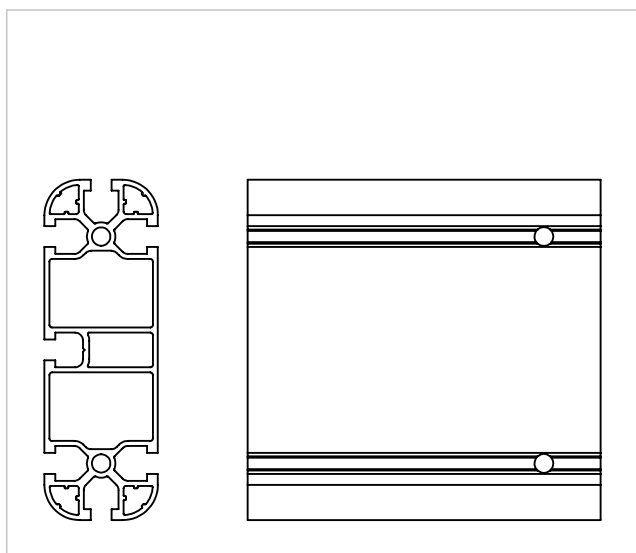
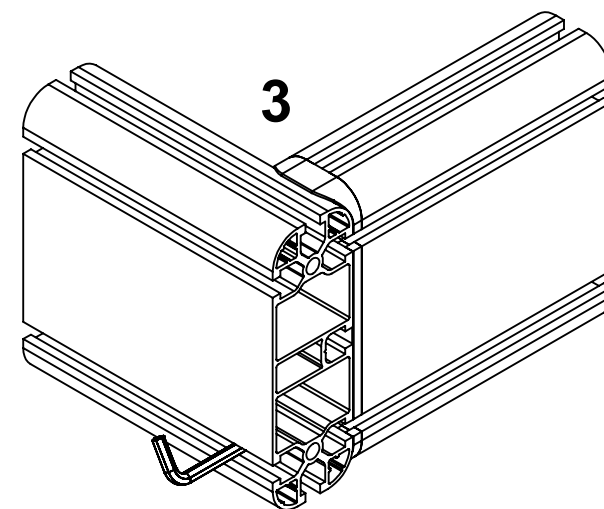
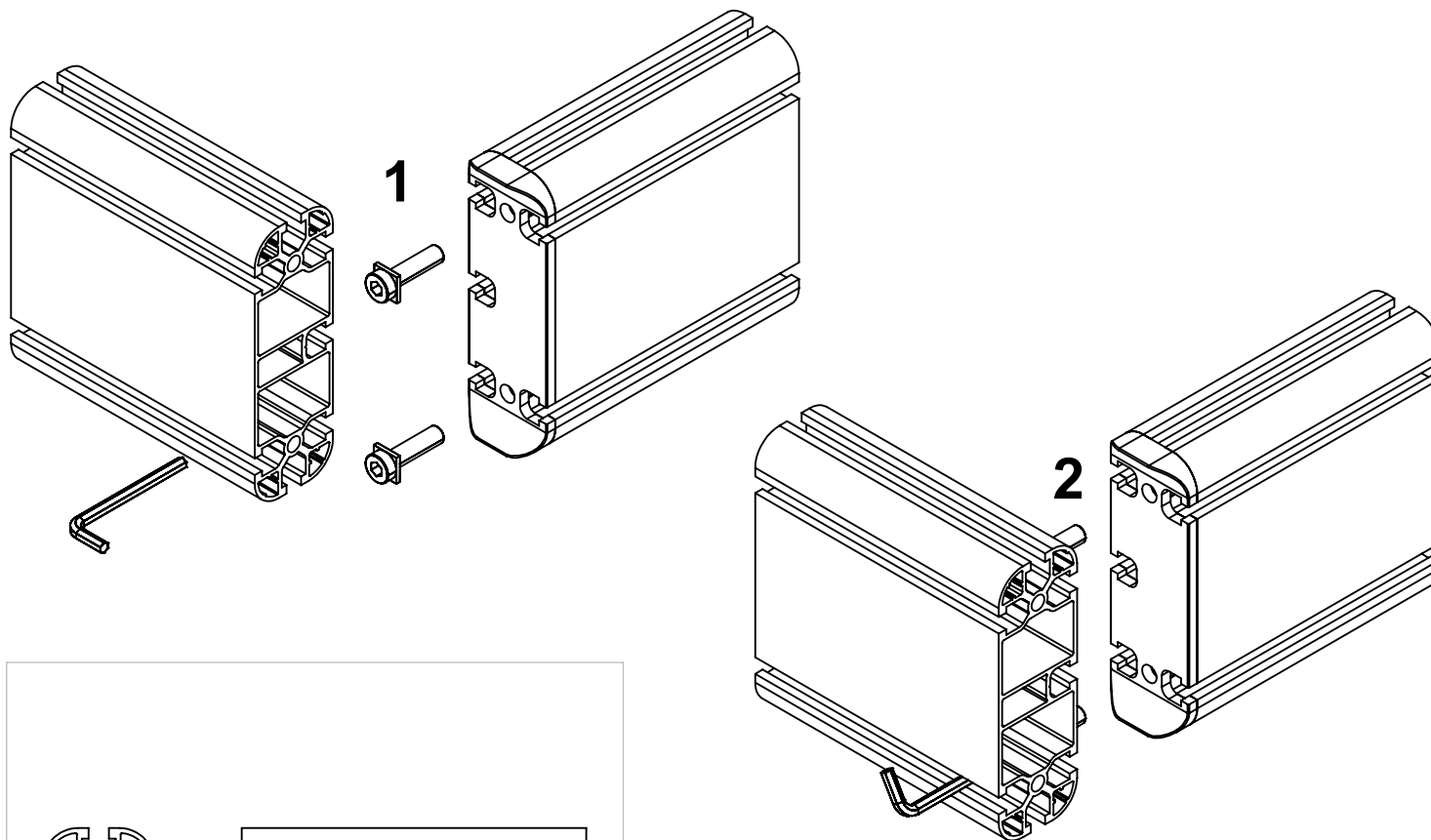

ITA- Vite a testa ribassata
ENG- Low head screw

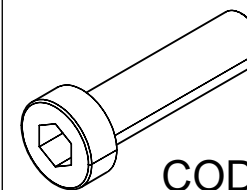

COD.CVITB0000023

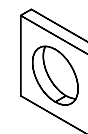

COD.CROY0000013

Foro passaggio chiave:

ITA- In questo diagramma potete vedere un altro modo per eseguire il fissaggio.

Hex wrenches passage hole:

ENG- In this diagram, you can see another way to do the fixing.

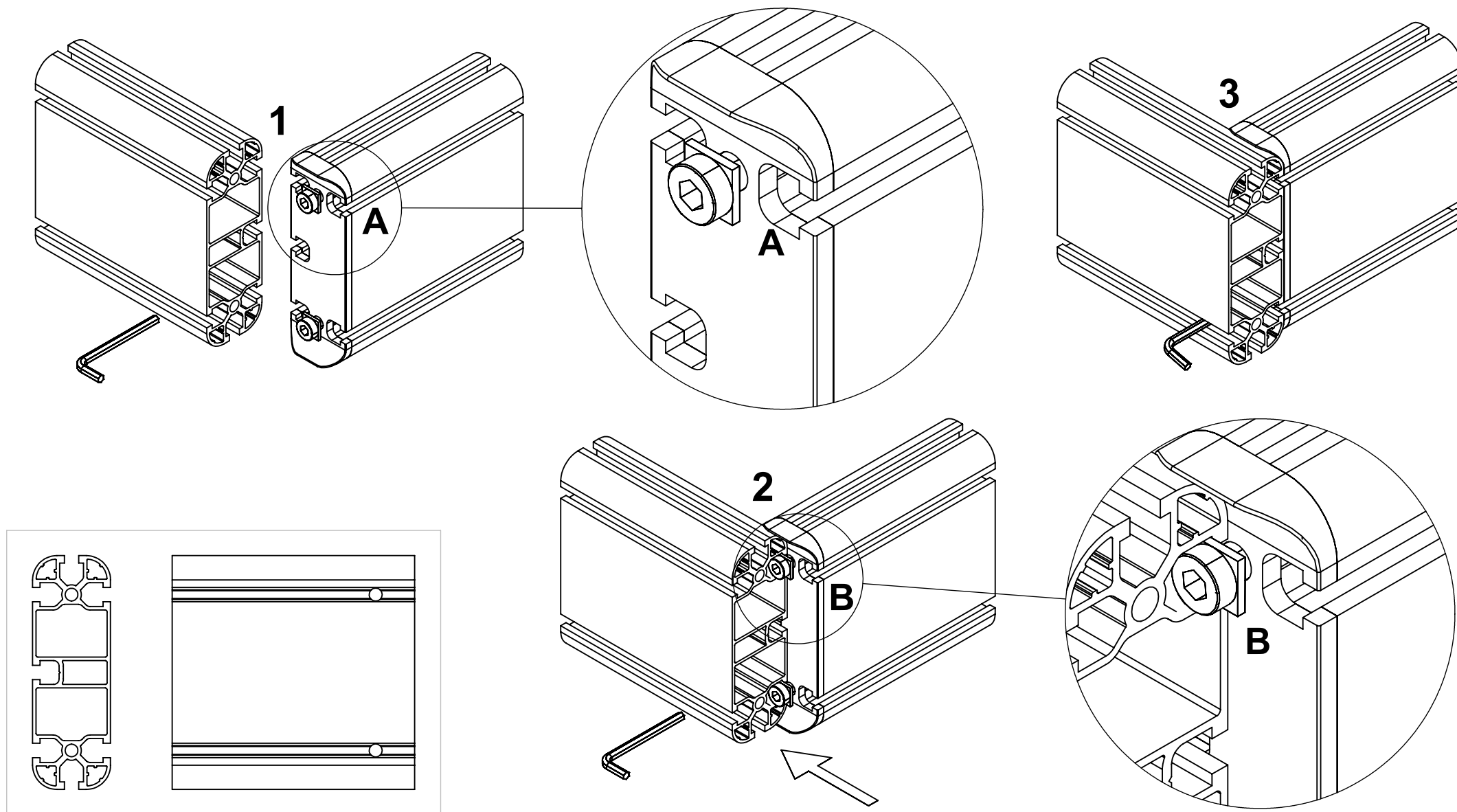

Inserimento tappi e giunti:

ITA- In questo diagramma potete vedere come inserire un tappo o un giunto. Potete anche usare il martello in gomma per incastrare il tappo o il giunto. Colpite la parte piatta del giunto, non occorre molta forza.

Inserting caps and joints:

ENG- In this diagram, you can see how to insert a cap or joint. You can also use the rubber hammer to tap in the cap or joint. Hit the flat part of the joint, it doesn't take much force.

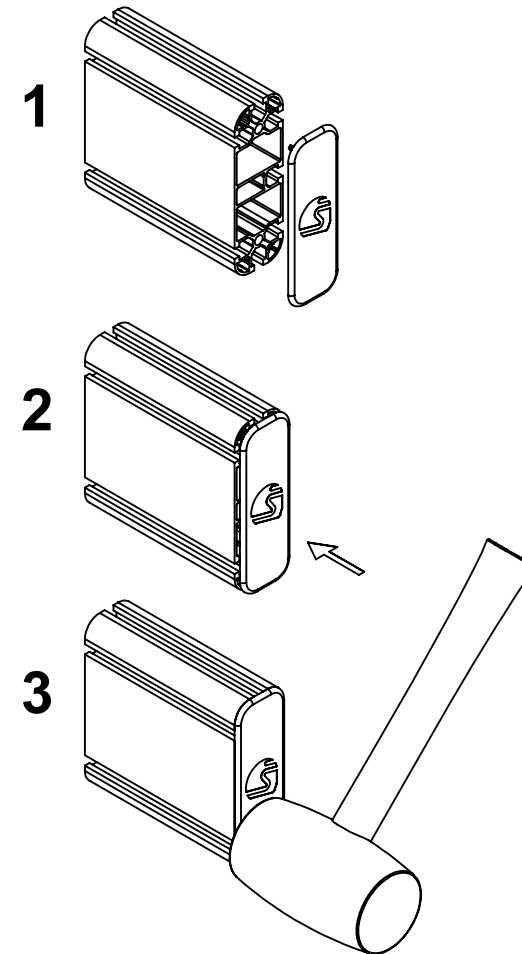
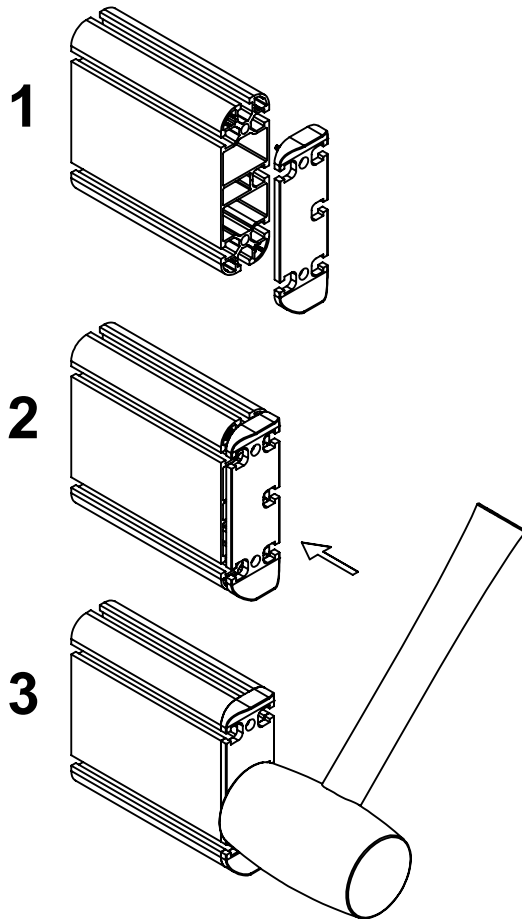

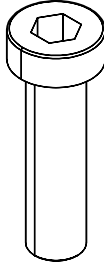
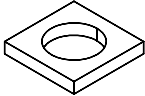
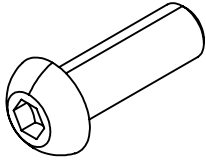
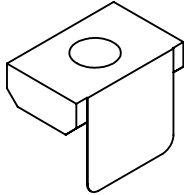
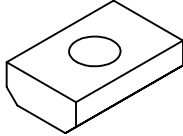
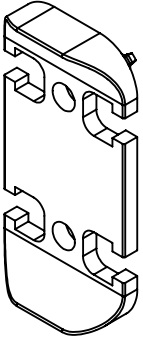
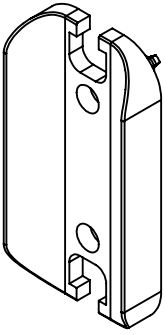
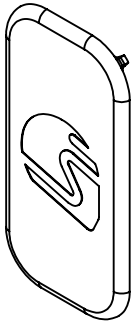
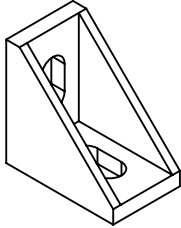
<p>DIN 7984 M8X30 COD.CVITB0000023 4 PZ</p> <p>SA.01.POP.03</p>	<p>13X13X2 COD.CROY0000013 4 PZ</p> <p>SA.01.POP.03</p>	<p>ISO 7380 M8X20 42 PZ</p> <p>SA.01.POP.03</p>	<p>M8 13X20X6 COD.DDDCU0000038 32 PZ</p> <p>SA.01.POP.03</p>	<p>M8 13X20X6 COD.DDDCU0000037 10 PZ</p> <p>SA.01.POP.03</p>	
					
<p>GO.14.45.090.N 2 PZ</p> <p>SA.02.POP.03</p>	<p>GV.14.45.090.N 2 PZ</p> <p>SA.02.POP.03</p>	<p>TI.15.45.090.N 6 PZ</p> <p>SA.02.POP.03</p>	<p>DSQAL0000005 4 PZ</p> <p>SA.03.POP.03</p>		
					

ITA- COSA C'È NELLA SCATOLA
ENG- WHAT'S IN THE BOX

DIM: 55 X 55 X H 20
WEIGHT: 15 KG
COD: KI.POP.03.NO

PR.090.N.L400.ST	2PZ
PR.090.N.L400.FI	2PZ
PR.090.N.L600.FO	1PZ
PE.PI.05.09.N.ST	4PZ
PE.PI.05.10.N.TP	1PZ
SA.01.POP.03 :	
COD.CVITB0000023	4PZ
COD.CROY0000013	4PZ
ISO 7380 M8X20	42PZ
COD.DDDCU0000038	32PZ
COD.DDDCU0000037	10PZ
SA.02.POP.03 :	
TI.15.45.090.N	6PZ
GO.14.45.090.N	2PZ
GV.14.45.090.N	2PZ
SA.03.POP.03 :	
DSQAL0000005	4PZ

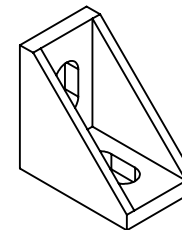
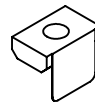
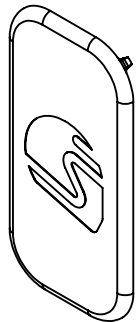
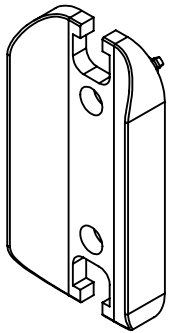
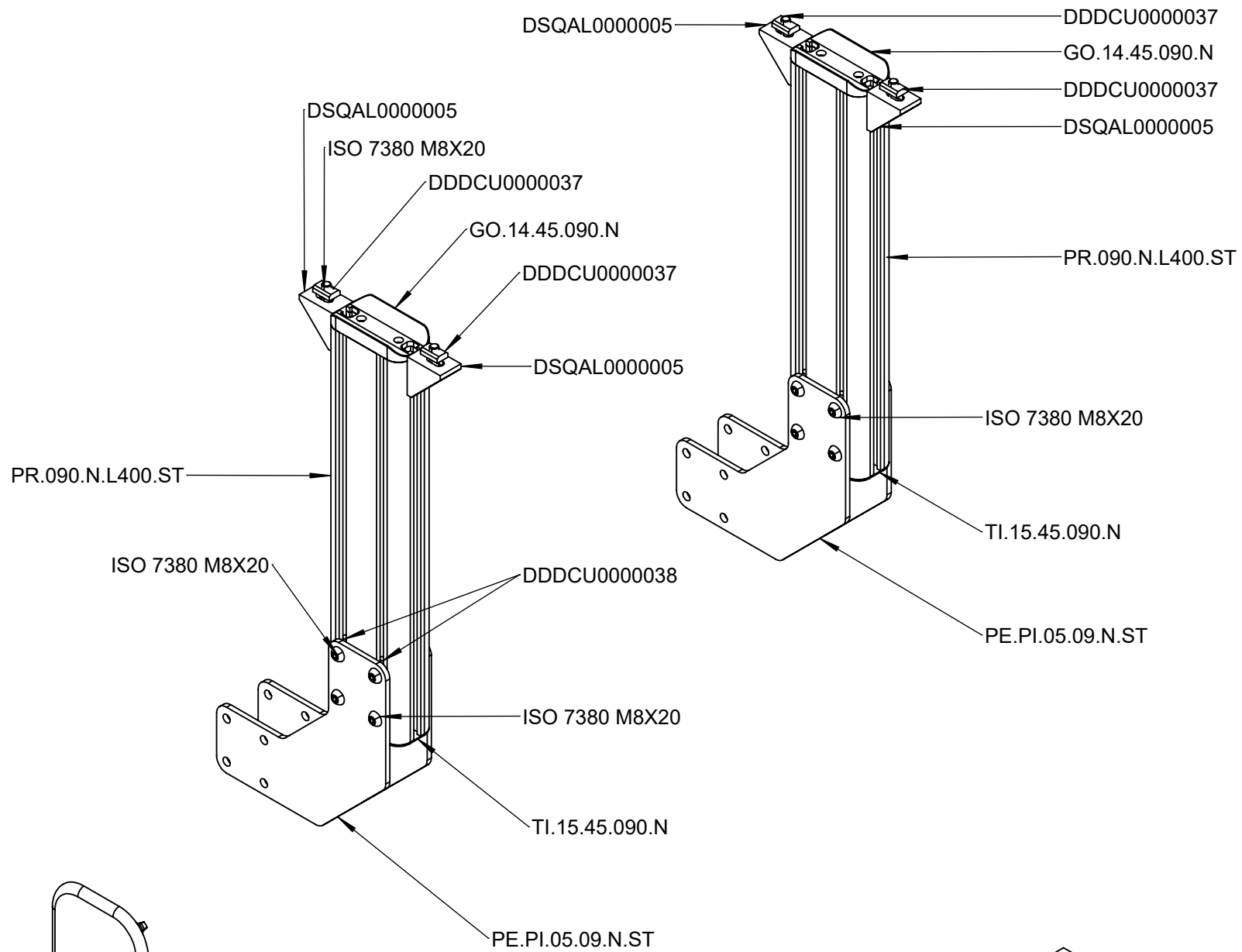

2X
GO.14.45.090.N

2X
TI.15.45.090.N

24X
ISO 7380 M8X20

8X
COD.DDDCU0000037

16X
COD.DDDCU0000038

4X
DSQAL0000005

DDDCU0000038

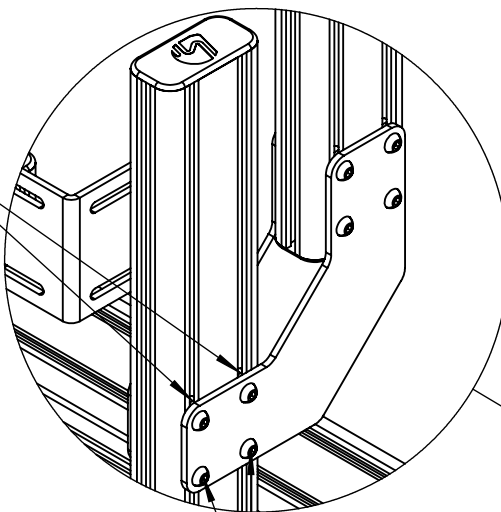

ISO 7380 M8X20

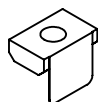
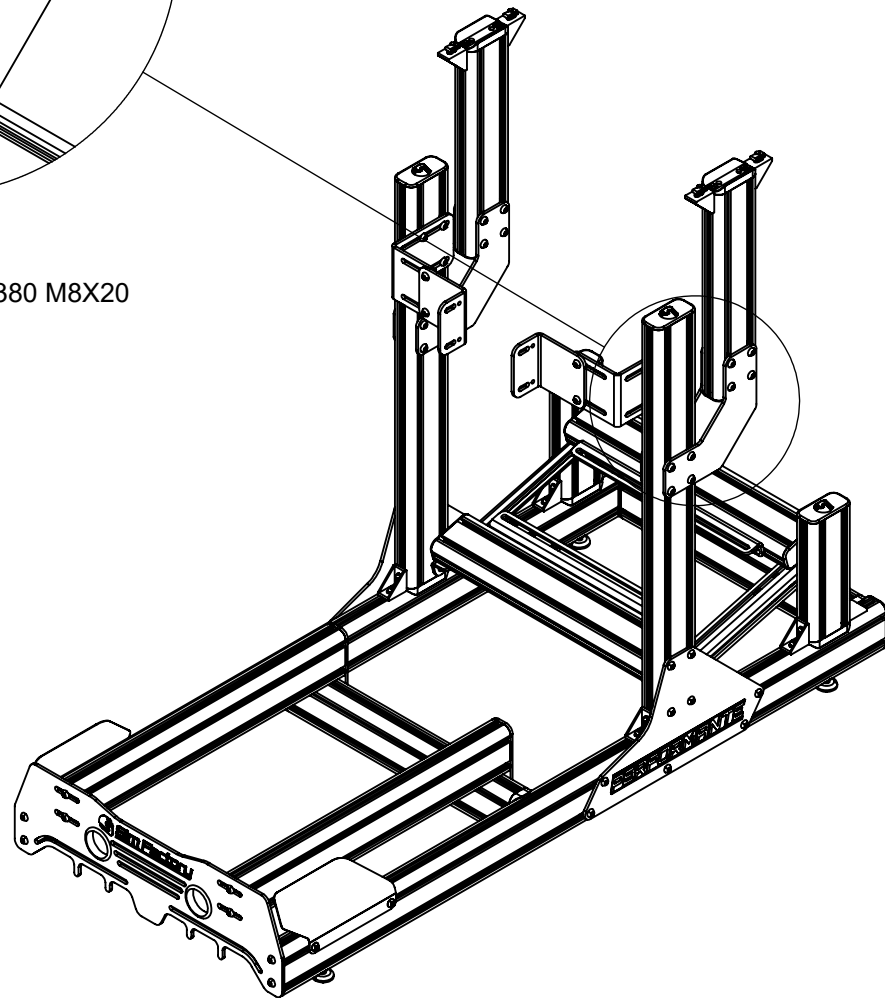
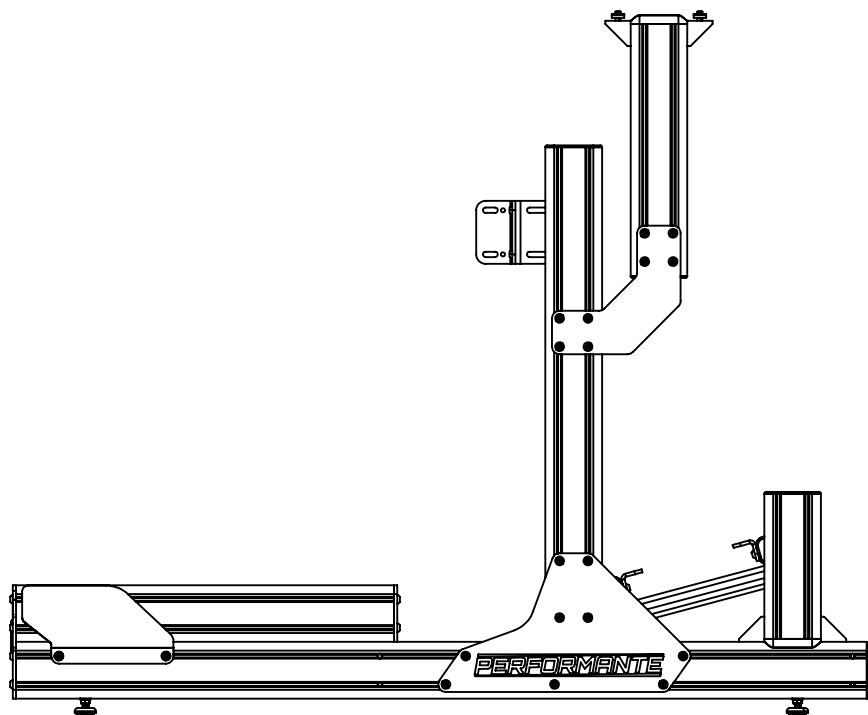

16X

COD.DDDCU0000038



16X

ISO 7380 M8X20

COD.CVITB0000023

COD.CROY0000013

PR.090.N.L400.FI

PR.090.N.L400.FI

GO.14.45.090.N

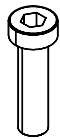
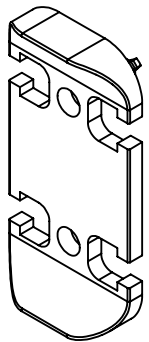

2X

4X

4X

GO.14.45.090.N

COD.CVITB0000023

COD.CROY0000013

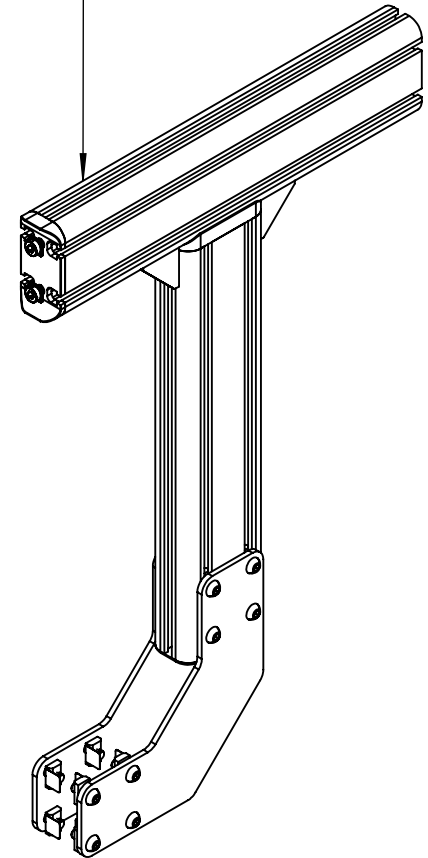
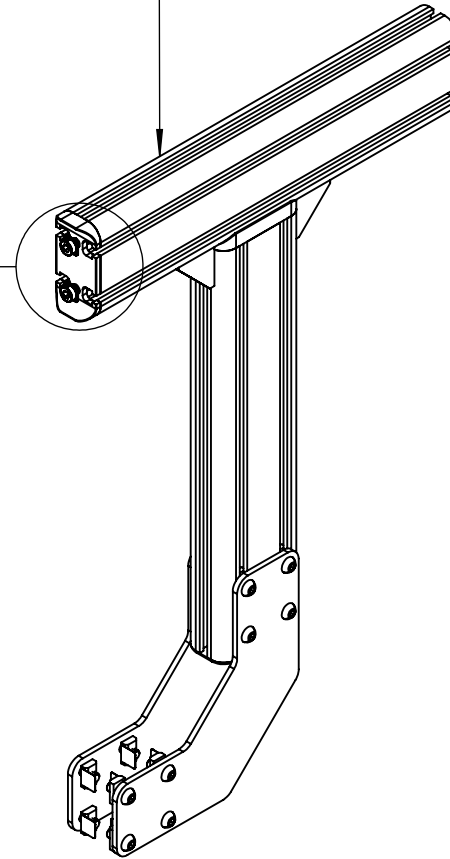
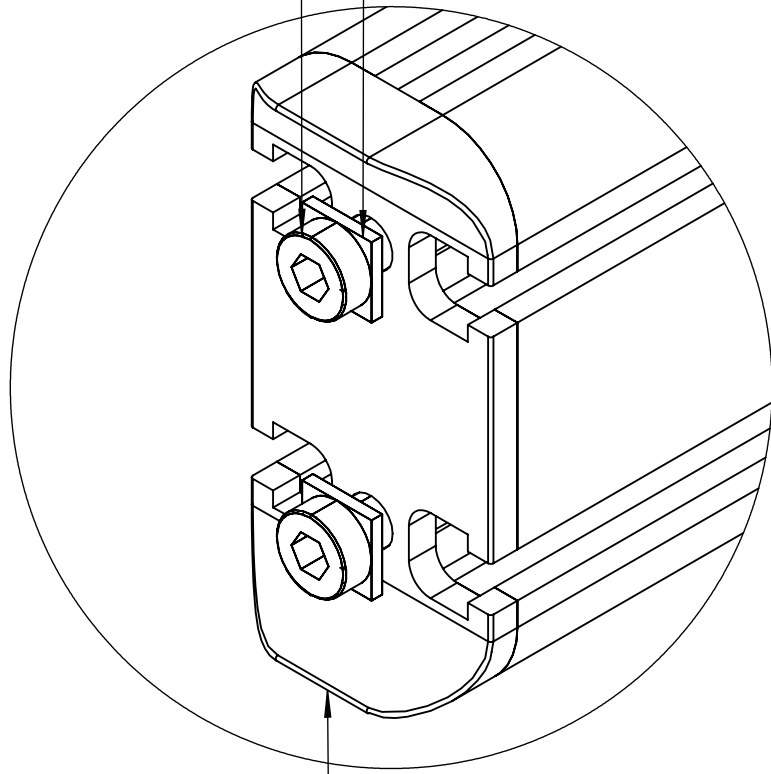

ITA- Fissate PE.PI.05.10.N.TP sul monitor prima di installarla PERFORMANTE COCKPIT MOUNTED MONITOR.
ENG- Fix PE.PI.05.10.N.TP to the monitor before installing it on the PERFORMANTE COCKPIT MOUNTED MONITOR.

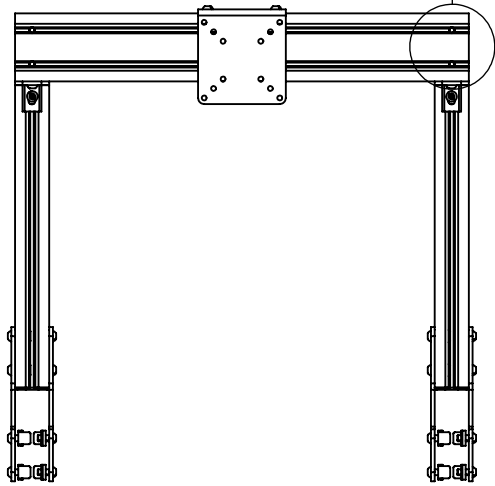
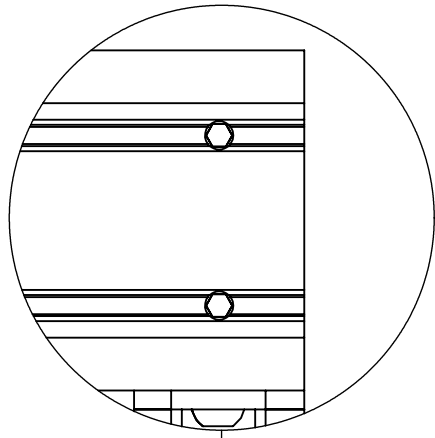

PE.PI.05.10.N.TP

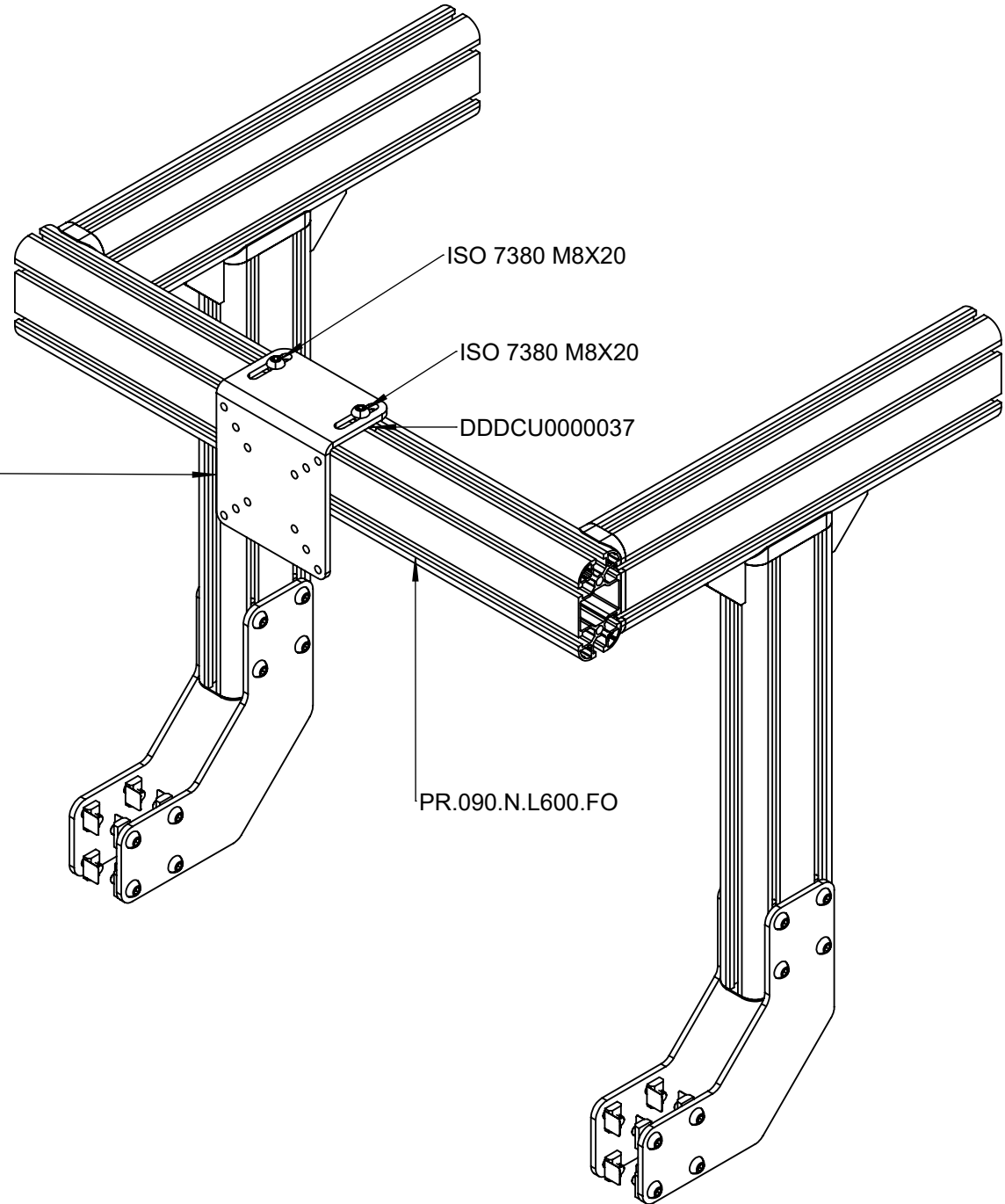

ISO 7380 M8X20

ISO 7380 M8X20

DDDCU0000037

PR.090.N.L600.FO

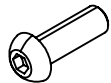

2X
ISO 7380 M8X20



2X
COD.DDDCU0000037

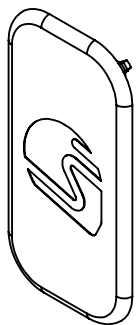
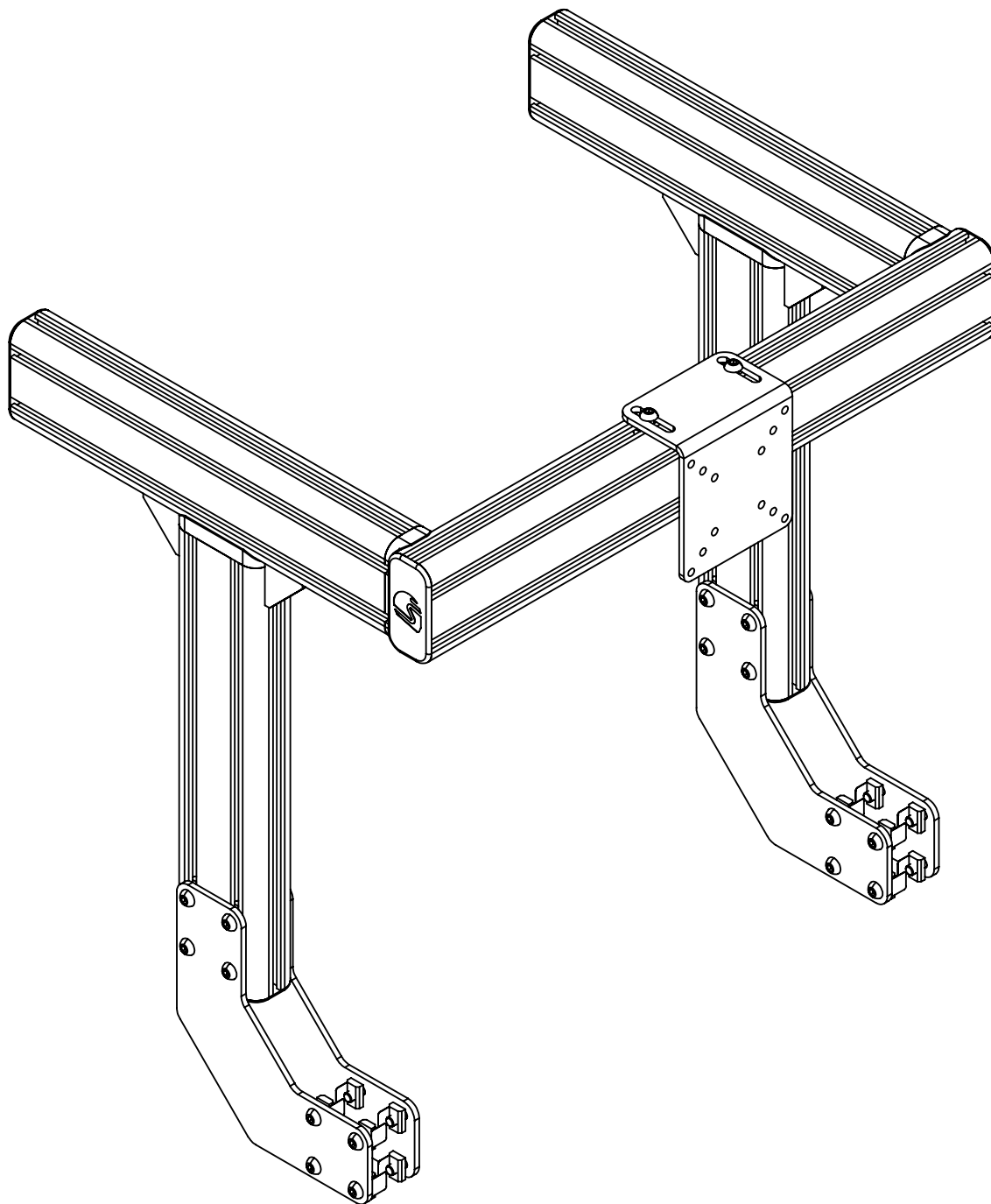

4X
TI.15.45.090.N