

MANUALE DI ISTRUZIONI - INSTRUCTION MANUAL

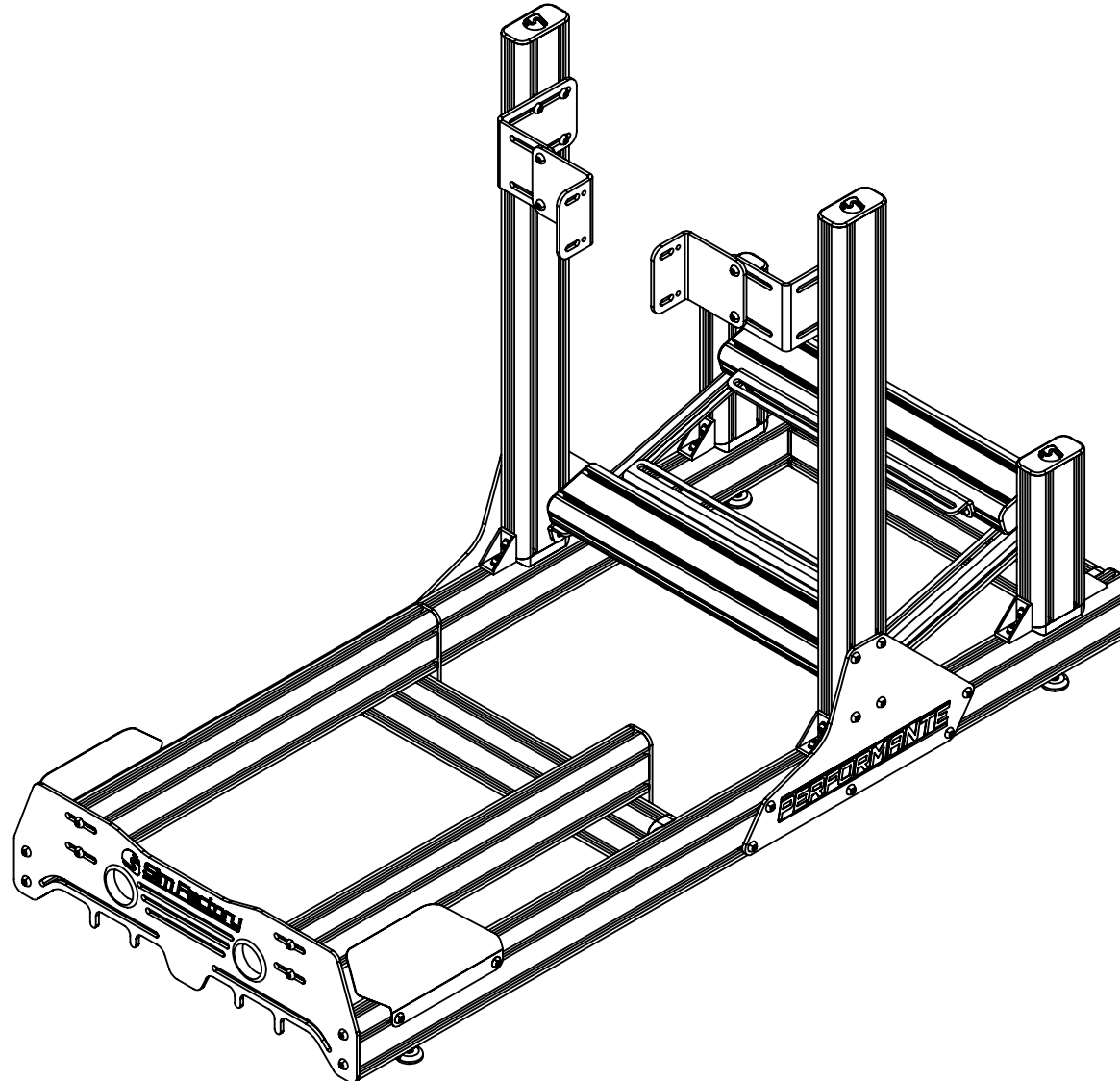

PERFORMANTE

PRIMA DI PARTIRE:

ITA- Grazie per aver acquistato questo prodotto Sim Factory!
Nelle pagine seguenti troverete istruzioni dettagliate sull'assemblaggio.
Ciò richiede degli strumenti semplici e un po' del vostro tempo.

A seconda del prodotto scelto l'assemblaggio può richiedere da qualche minuto a molte ore, ma adorerete ogni minuto speso per dar forma al vostro prodotto Sim Factory.

BEFORE YOU START:

ENG- Thank you for purchasing this Sim Factory product!
On the following pages, you will find detailed instructions on assembly.
This requires only a set of simple tools and some of your time.

Depending on the product chosen assembly can take from a few minutes to many hours, but you will love every minute spent on shaping your Sim Factory product.

ITA- Strumenti necessari:

ENG- Tools needed:

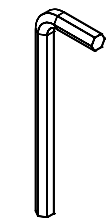

4mm
5mm
6mm

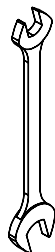

13mm
17mm

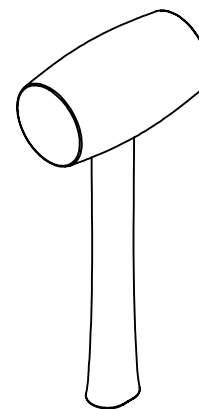

martello in gomma
rubber hammer

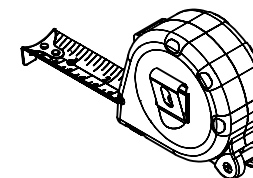

Inserimento cursori:

ITA- In questo diagramma potete vedere come inserire un cursore direttamente nella cava. Potete anche usare una delle chiavi esagonali più piccole per aiutarvi a muovere il cursore in posizione.

Inserting Slot-Nuts:

ENG- In this diagram, you can see how to insert a Slot-Nut directly into the slot from the side. You can also use one of your smaller Hex wrenches to help wiggle the Slot-Nut in place.

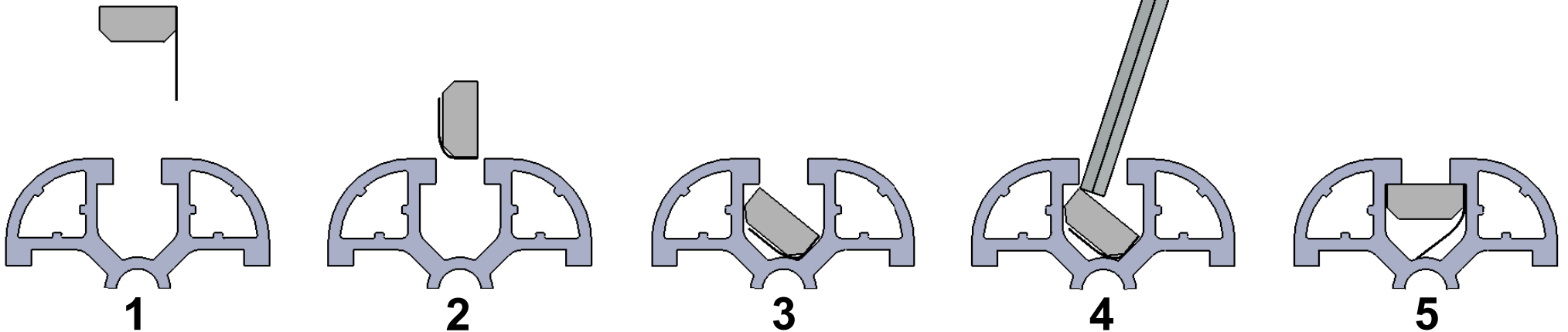
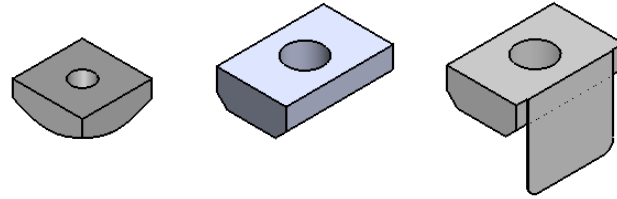

Foro passaggio chiave:

ITA- In questo diagramma potete vedere come eseguire il fissaggio correttamente.

Hex wrenches passage hole:

ENG- In this diagram, you can see how to fixing correctly.

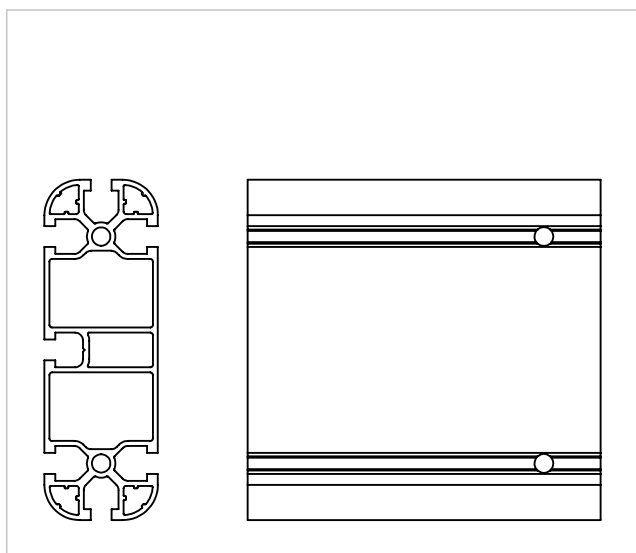
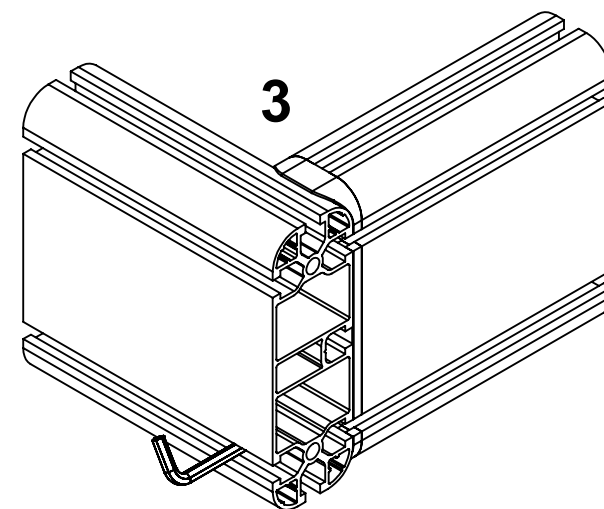
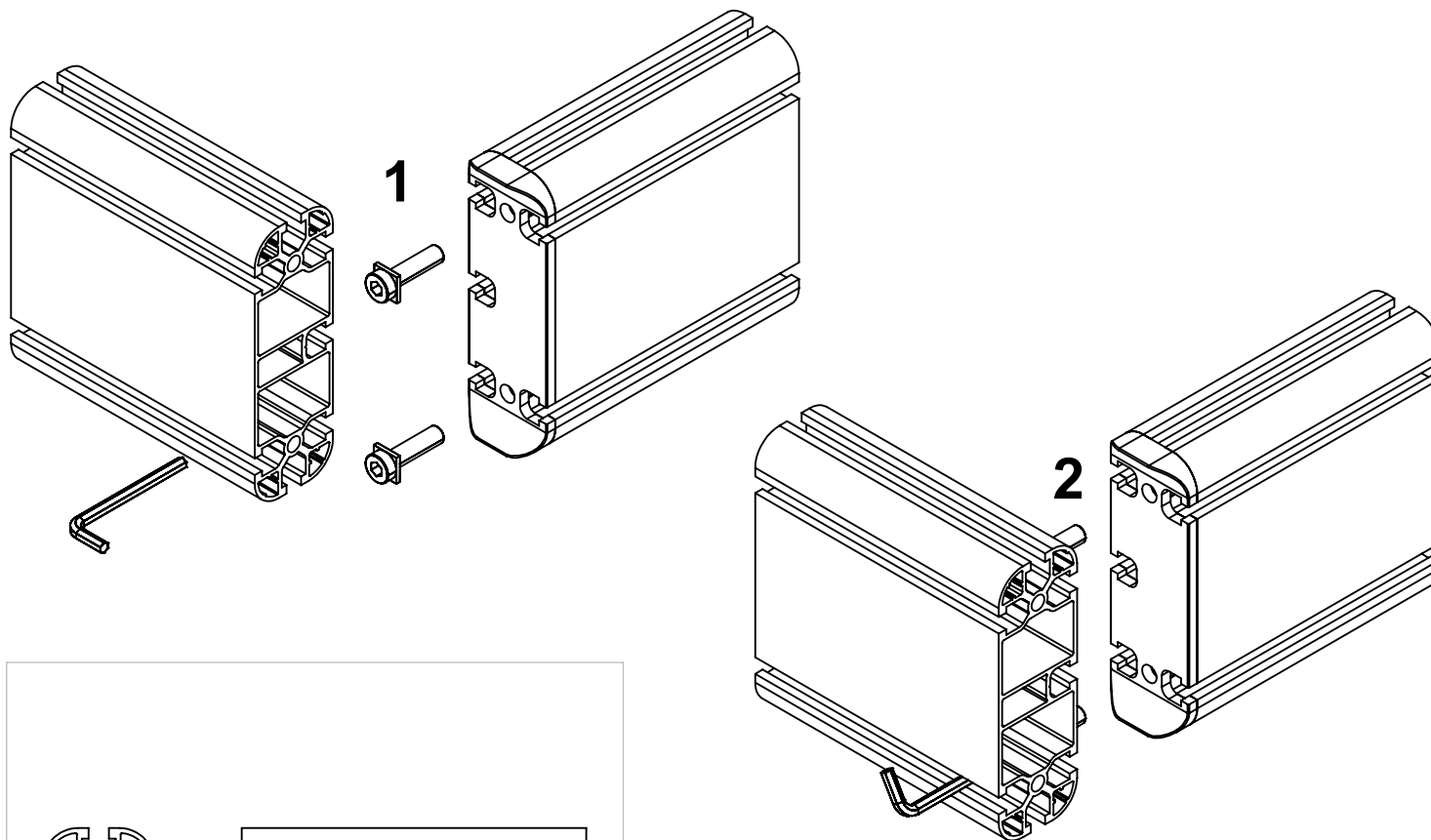

ITA- Vite a testa ribassata
ENG- Low head screw

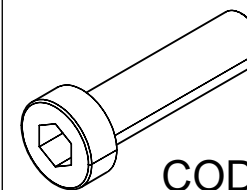

COD.CVITB0000023

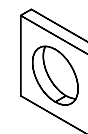

COD.CROY0000013

Foro passaggio chiave:

ITA- In questo diagramma potete vedere un altro modo per eseguire il fissaggio.

Hex wrenches passage hole:

ENG- In this diagram, you can see another way to do the fixing.

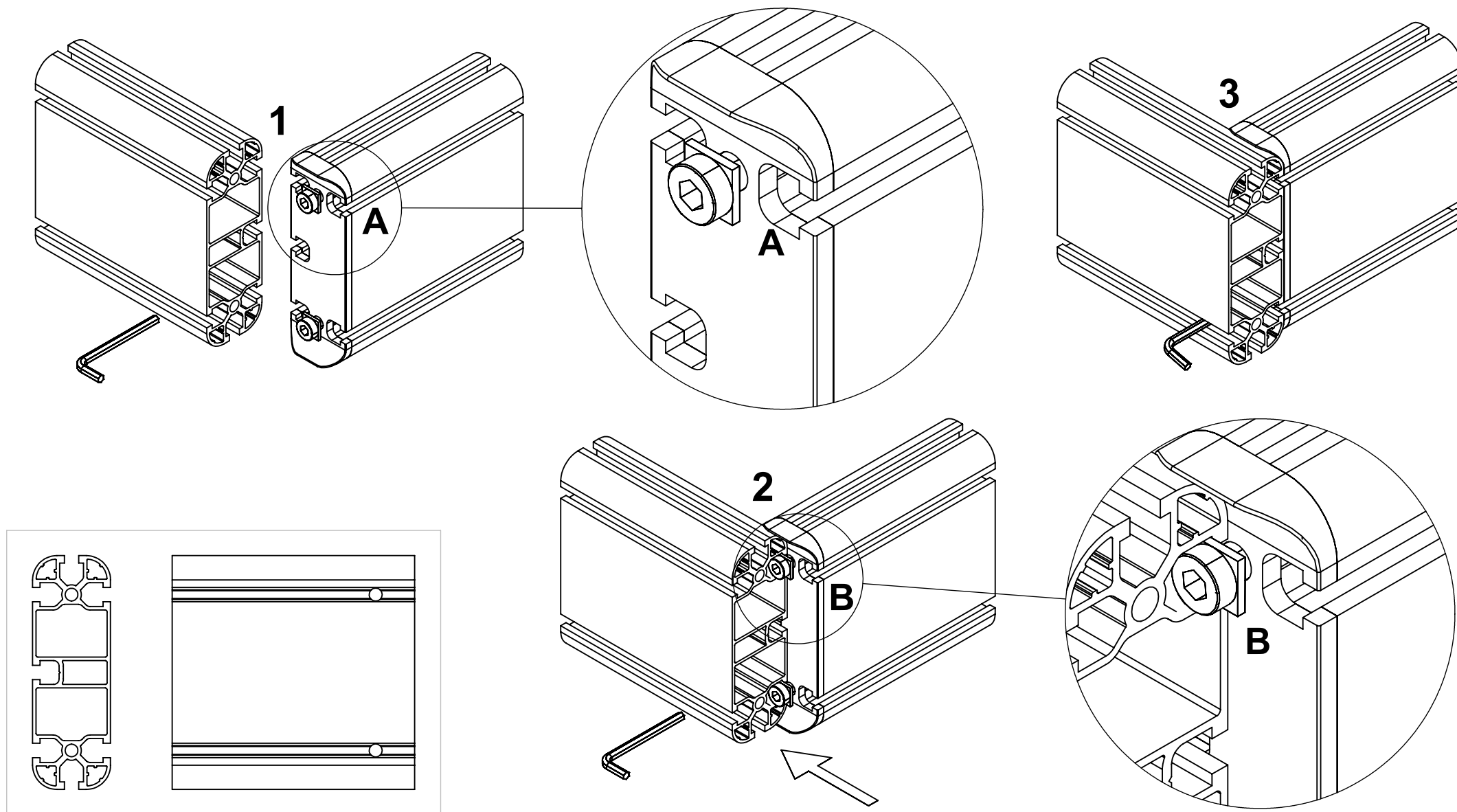



Inserimento tappi e giunti:

ITA- In questo diagramma potete vedere come inserire un tappo o un giunto. Potete anche usare il martello in gomma per incastrare il tappo o il giunto. Colpite la parte piatta del giunto, non occorre molta forza.

Inserting caps and joints:

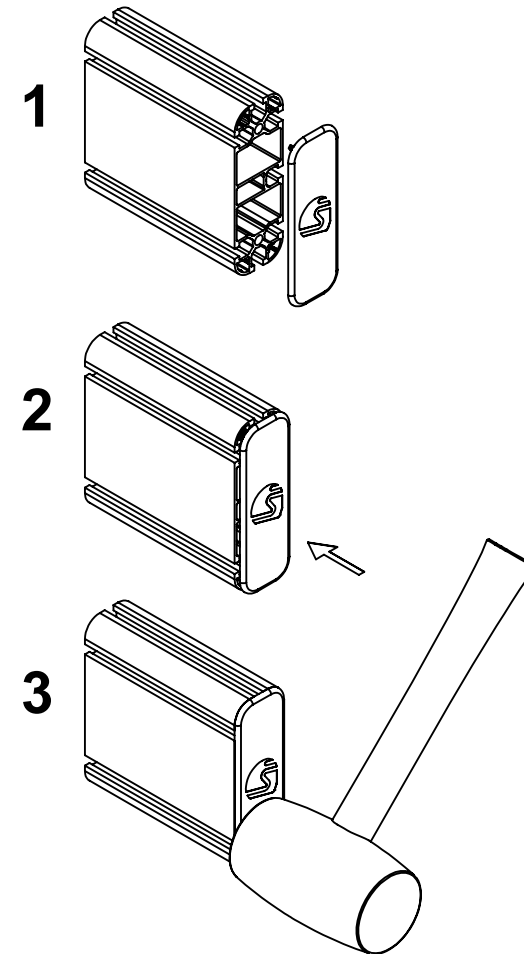
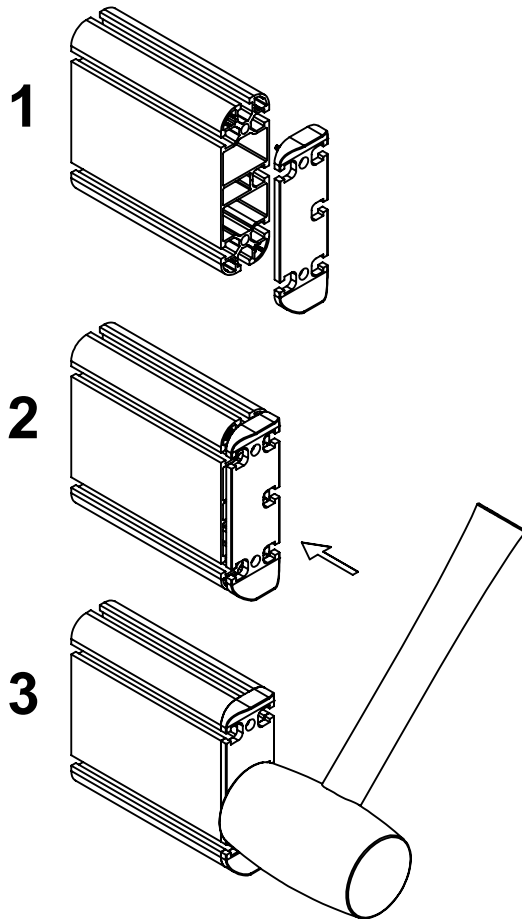
ENG- In this diagram, you can see how to insert a cup or joint. You can also use the rubber hammer to tap in the cap or joint. Hit the flat part of the joint, it doesn't take much force.

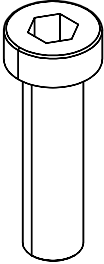
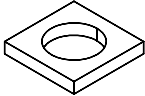

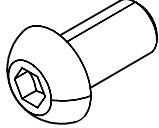
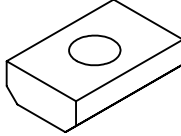
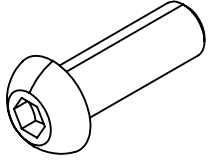
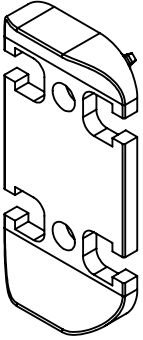
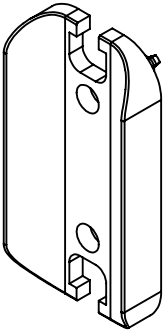
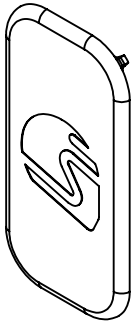
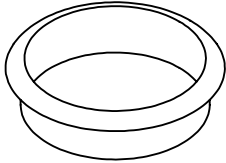
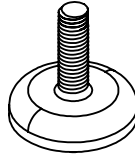
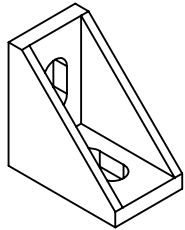
| | | | | | |
|---|---|---|--|--|---|
| <p>DIN 7984 M8X30 COD.CVITB0000023 8 PZ</p> <p>SA.01.PER.01</p>  | <p>13X13X2 COD.CROY0000013 8 PZ</p> <p>SA.01.PER.01</p>  | <p>DADO DIN 6923 M8 FLANGIATO QUANTITA': 8 PZ</p> <p>SA.01.PER.01</p>  | <p>ISO 7380 M8X16 4 PZ</p> <p>SA.01.PER.01</p>  | <p>M8 13X20X6 COD.DDDCU0000037 74 PZ</p> <p>SA.02.PER.01</p>  | <p>ISO 7380 M8X20 82 PZ</p> <p>SA.03.PER.01</p>  |
| <p>GO.14.45.090.N 4 PZ</p> <p>SA.04.PER.01</p>  | <p>GV.14.45.090.N 4 PZ</p> <p>SA.04.PER.01</p>  | <p>TI.15.45.090.N 10 PZ</p> <p>SA.04.PER.01</p>  | <p>0050435 Ø 50 mm 2 PZ</p> <p>SA.04.PER.01</p>  | <p>LKFF00301200407 4 PZ</p> <p>SA.04.PER.01</p>  | <p>DSQAL0000005 8 PZ</p> <p>SA.05.PER.01</p>  |

ITA- COSA C'È NELLA SCATOLA
ENG- WHAT'S IN THE BOX

DIM: 55 X 55 X H 20
WEIGHT: 18 KG
COD: KI.PER.01.NO-1

DIM: 150 X 25 X H 25
WEIGHT: 25 KG
COD: KI.PER.01.NO-2

| | | | |
|-------------------------|------------|--------------------------|------------|
| PE.PI.01.01.N.TP | 1PZ | PR.090.N.L230.ST | 2PZ |
| PE.PI.01.02.N.TP | 1PZ | PR.090.N.L490.ST | 2PZ |
| PE.PI.05.01.N.ST | 1PZ | PR.090.N.L500.FI | 2PZ |
| PE.PI.05.02.N.ST | 2PZ | PR.090.N.L600.FI | 2PZ |
| PE.PI.05.03.N.ST | 2PZ | PR.090.N.L780.ST | 2PZ |
| PE.PI.05.04.N.TP | 4PZ | PR.090.N.L1350.FF | 2PZ |
| PE.PI.05.05.N.TP | 2PZ | | |
| PE.PI.05.06.N.TP | 2PZ | | |
| SA.01.PER.01 : | | | |
| COD.CVITB0000023 | 8PZ | | |
| COD.CROY0000013 | 8PZ | | |
| DIN 6923 M8 | 8PZ | | |
| ISO 7380 M8X16 | 4PZ | | |
| SA.02.PER.01 : | | | |
| COD.DDDCU0000037 | 74PZ | | |
| SA.03.PER.01 : | | | |
| ISO 7380 M8X20 | 82PZ | | |
| SA.04.PER.01 : | | | |
| TI.15.45.090.N | 10PZ | | |
| GO.14.45.090.N | 4PZ | | |
| GV.14.45.090.N | 4PZ | | |
| 0050435 | 2PZ | | |
| LKFF00301200407 | 4PZ | | |
| SA.05.PER.01 : | | | |
| DSQAL0000005 | 8PZ | | |

PR.090.N.L1350.FF

PR.090.N.L1350.FF

PR.090.N.L500.FI

PR.090.N.L500.FI

ITA- Lato filettato.

ENG- Threaded side.

DDDCU0000037

DIN 6923 M8

LKFF00301200407

COD.CROY0000013

COD.CVITB0000023

GO.14.45.090.N

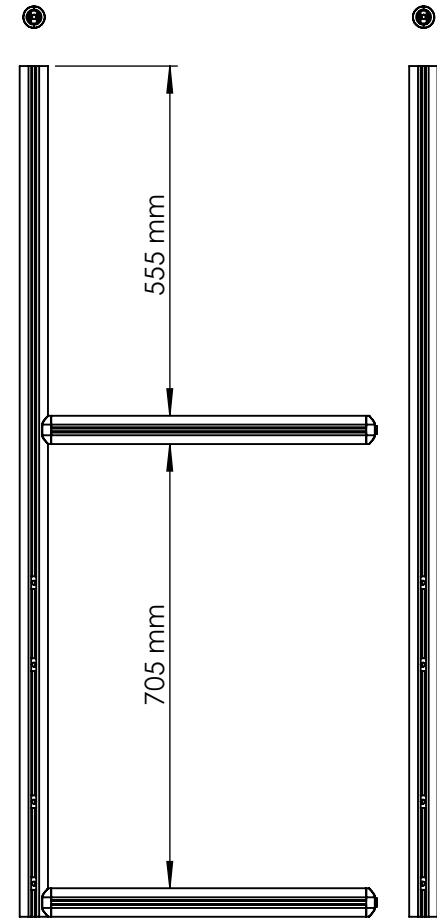
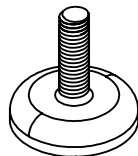
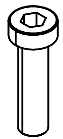
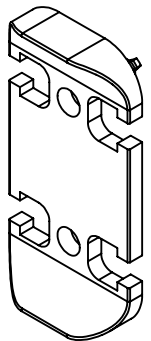

4X
GO.14.45.090.N

8X
COD.CVITB0000023

8X
COD.CROY0000013

4X
LKFF00301200407

4X
DIN 6923 M8

4X
COD.DDDCU0000037

ITA- Non stringere completamente le viti che fissano i profili PR.090.N.L600.FI
La distanza cambia a seconda del sedile.

ENG- Do not completely tighten the screws that fix the PR.090.N.L600.FI profiles.
The distance depending on the seat.

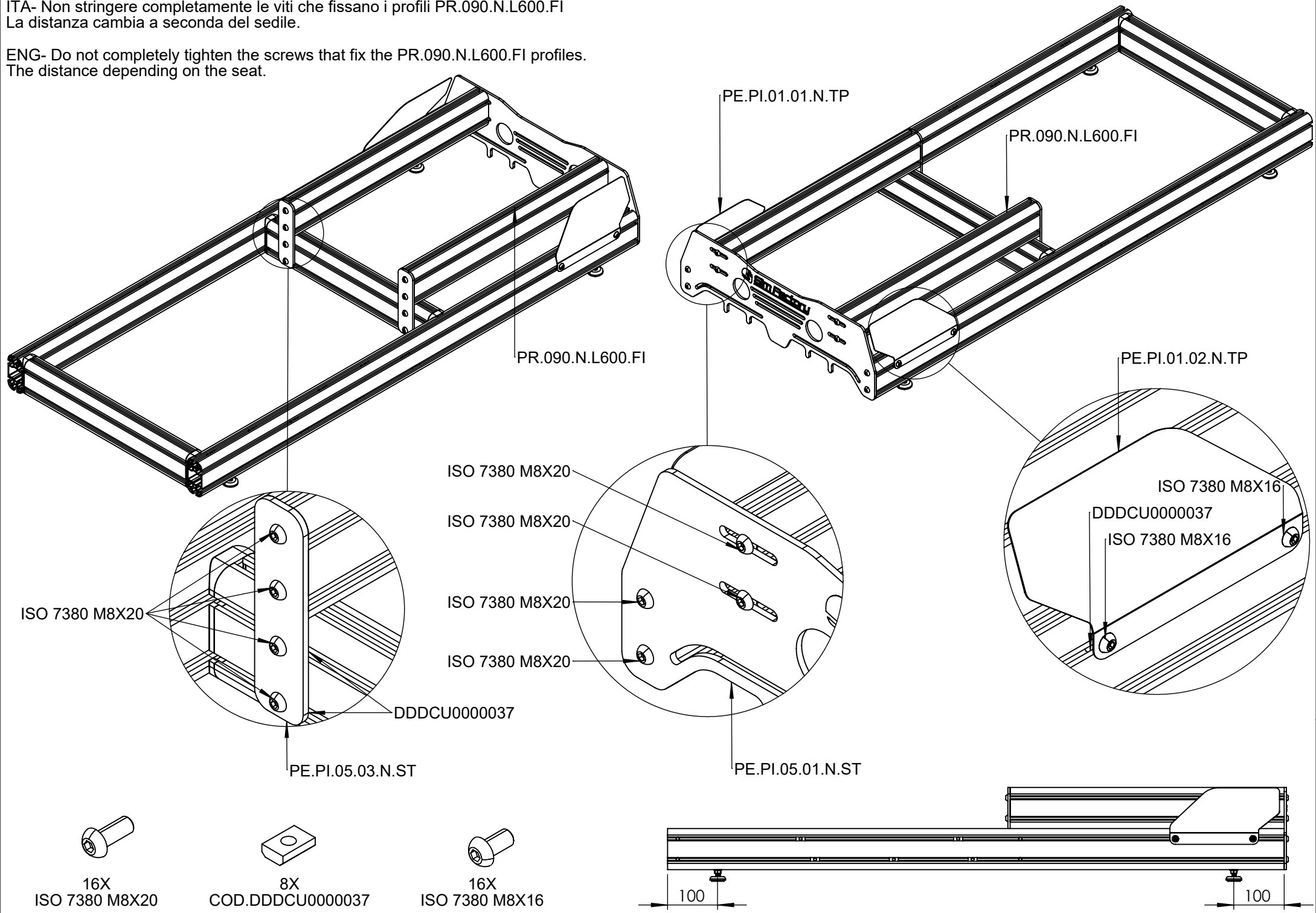

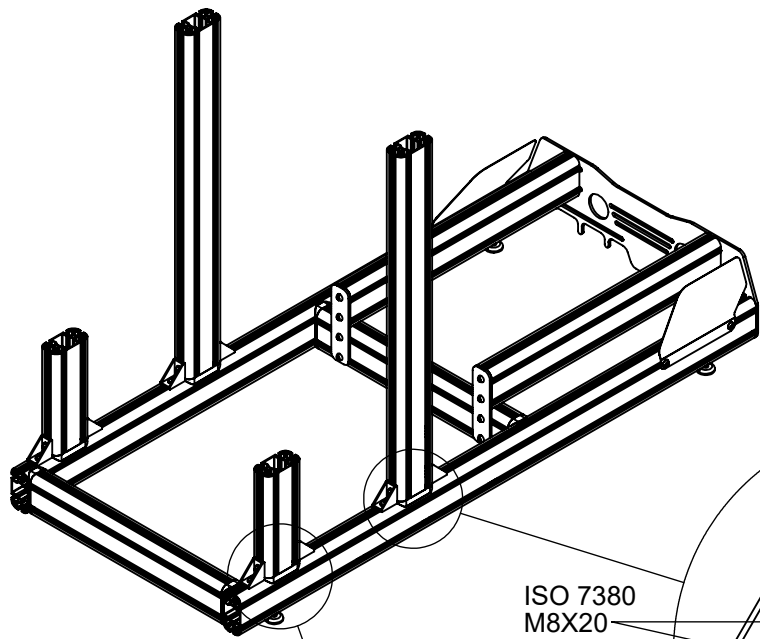

PR.090.N.L230.ST

PR.090.N.L780.ST

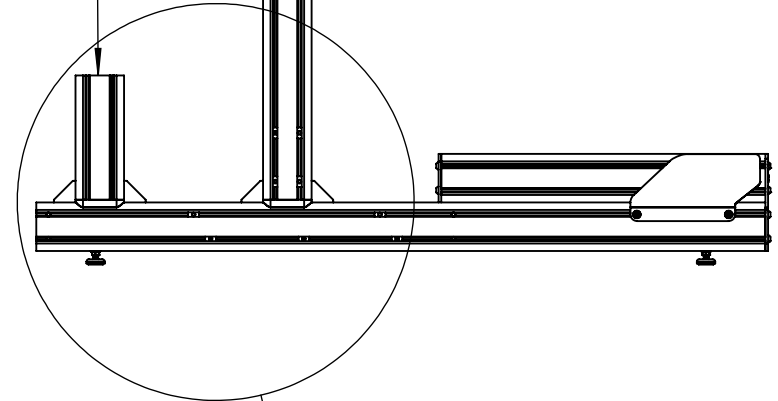

DSQAL0000005

ISO 7380
M8X20

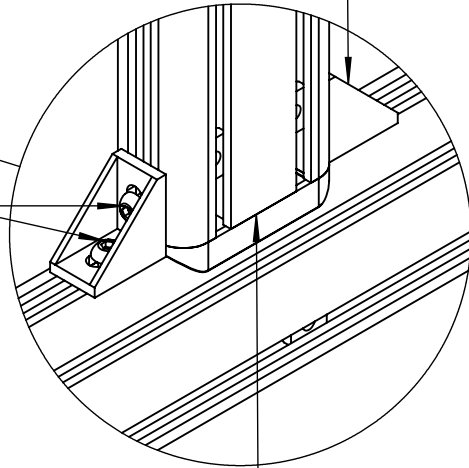

GV.14.45.090.N

DSQAL0000005

ISO 7380
M8X20

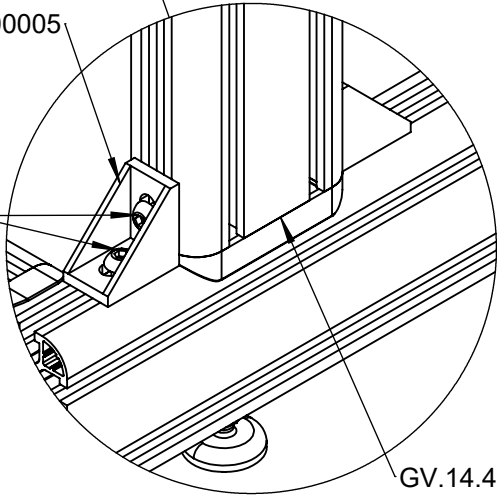

GV.14.45.090.N

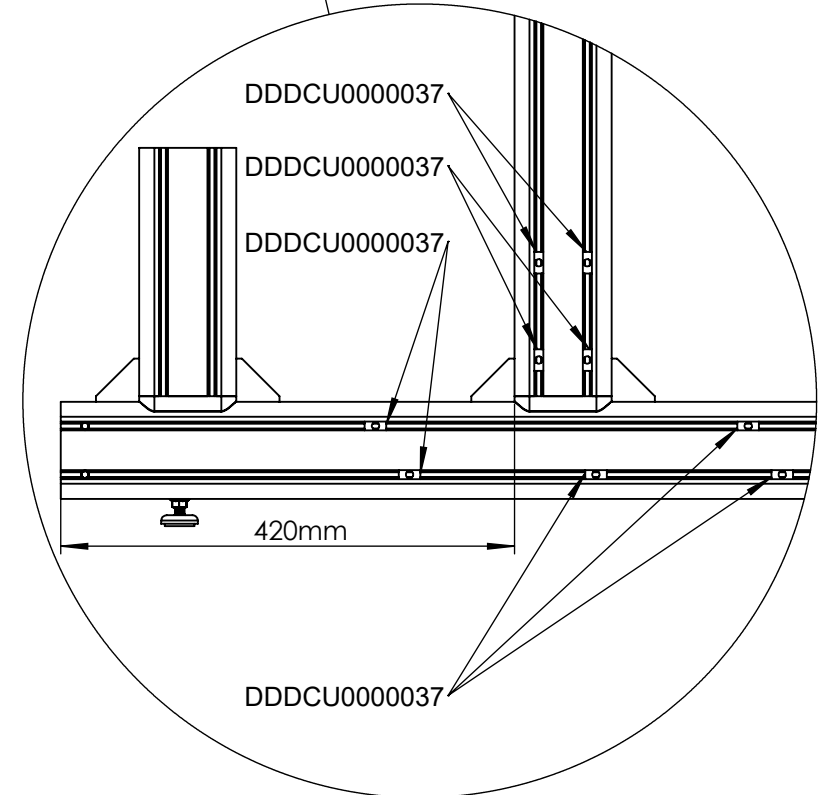

DDDCU0000037

DDDCU0000037

DDDCU0000037

DDDCU0000037

420mm

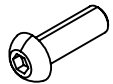

16X
ISO 7380 M8X20

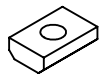

34X
COD.DDDCU0000037

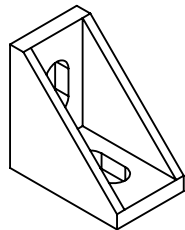

8X
DSQAL0000005

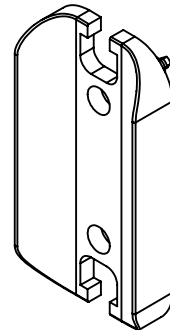

4X
GV.14.45.090.N

ITA- Per facilitare l'installazione di PE.PI.05.02.N.ST , si consiglia di posizionare sul fianco il telaio, prima da un lato poi dall'altro.

ENG- To facilitate the installation of PE.PI.05.02.N.ST, it is recommended to place the frame on its side, first on one side and then on the other.

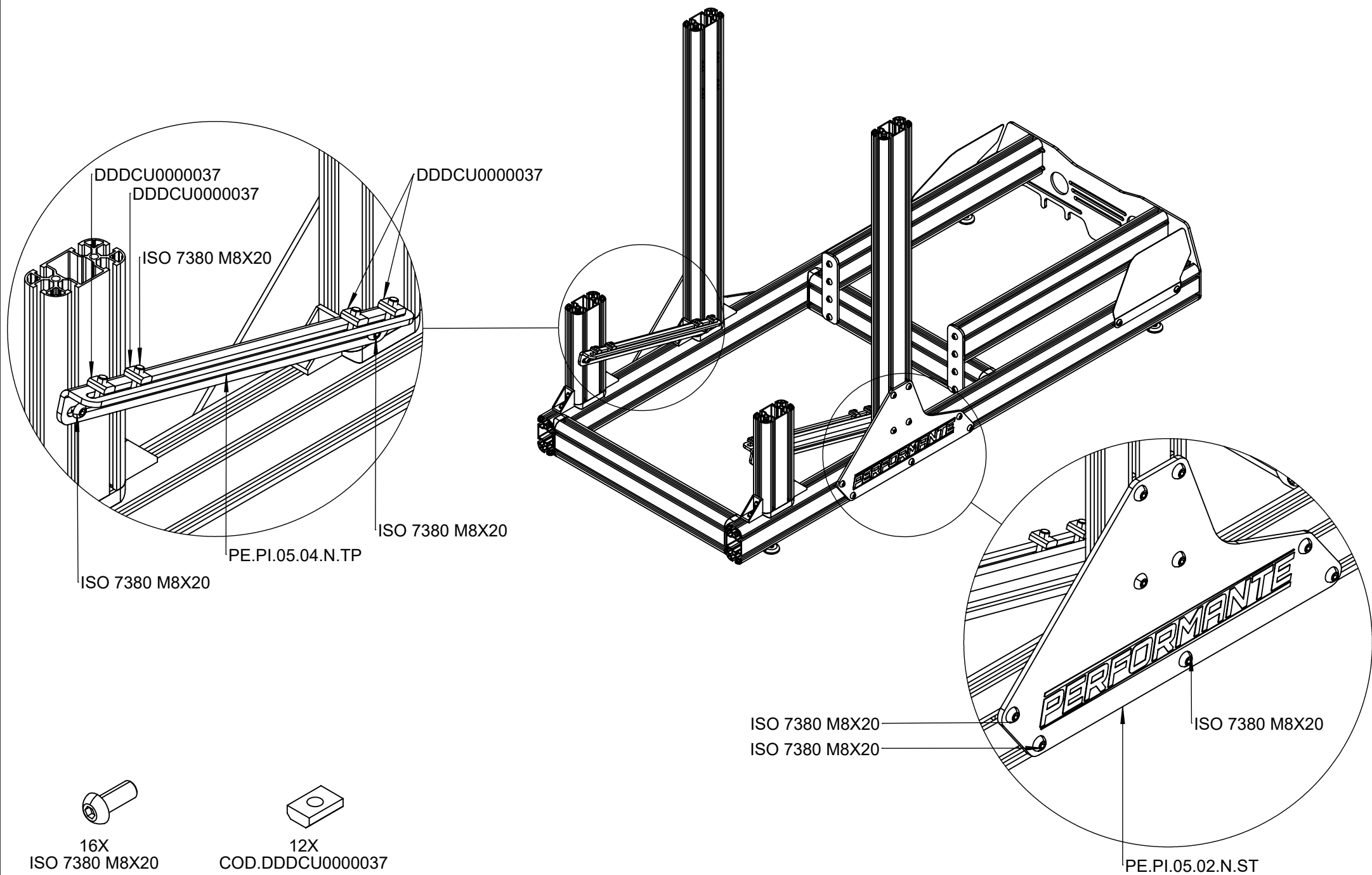

ITA- Per facilitare regolare l'inclinazione della pedaliera lasciare liberi di scorrere avanti e indietro i profili PR.090.N.L230.ST.
Stringere completamente le viti una volta raggiunta la posizione desiderata.

ENG- To facilitate adjusting the inclination of the pedal plate, allow the PR.090.N.L230.ST profiles to slide freely back and forth.
Fully tighten the screws once the desired position has been reached.

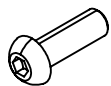
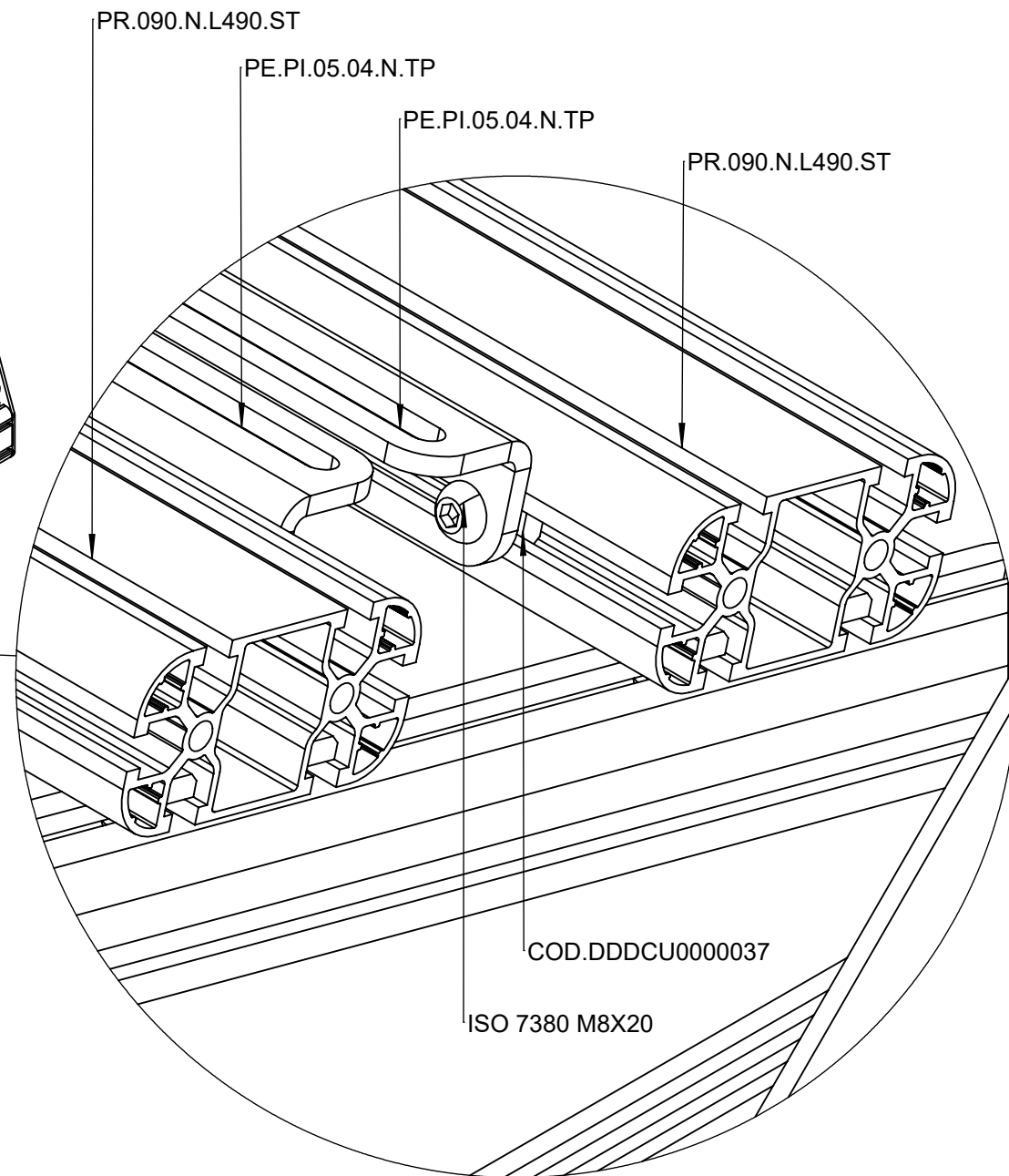
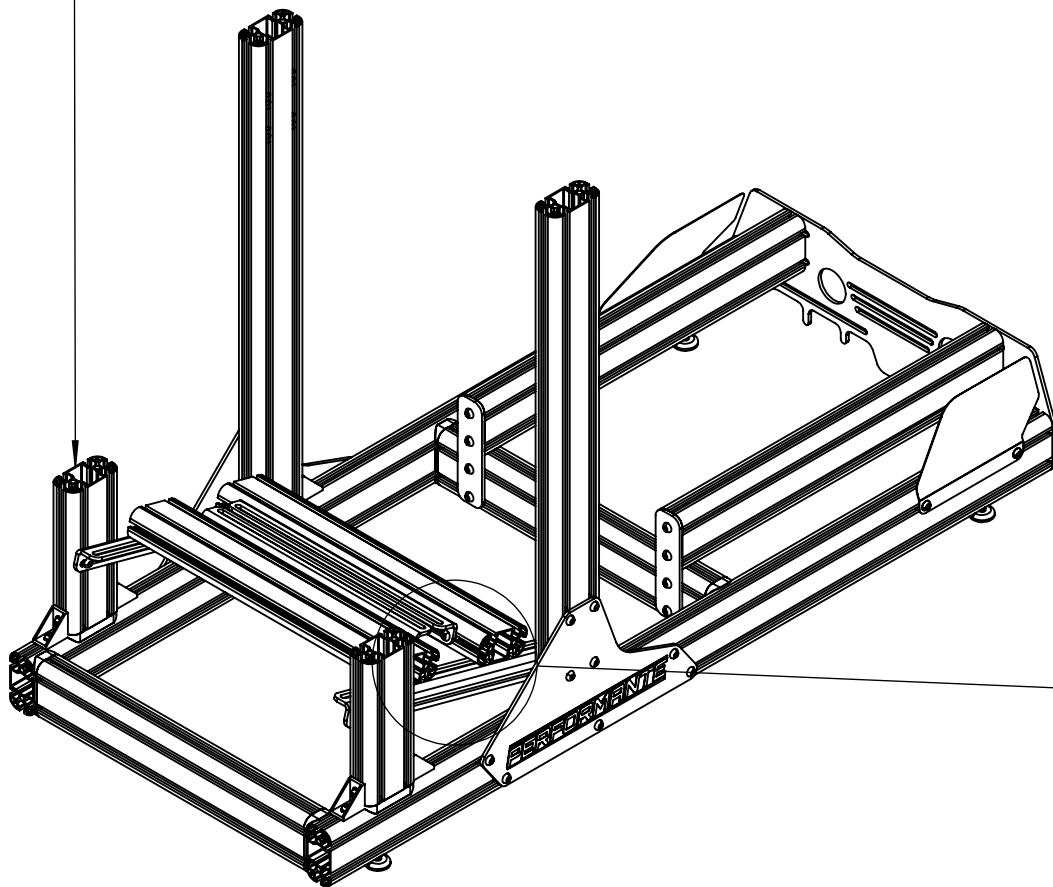

4X
ISO 7380 M8X20



4X
COD.DDDCU0000037

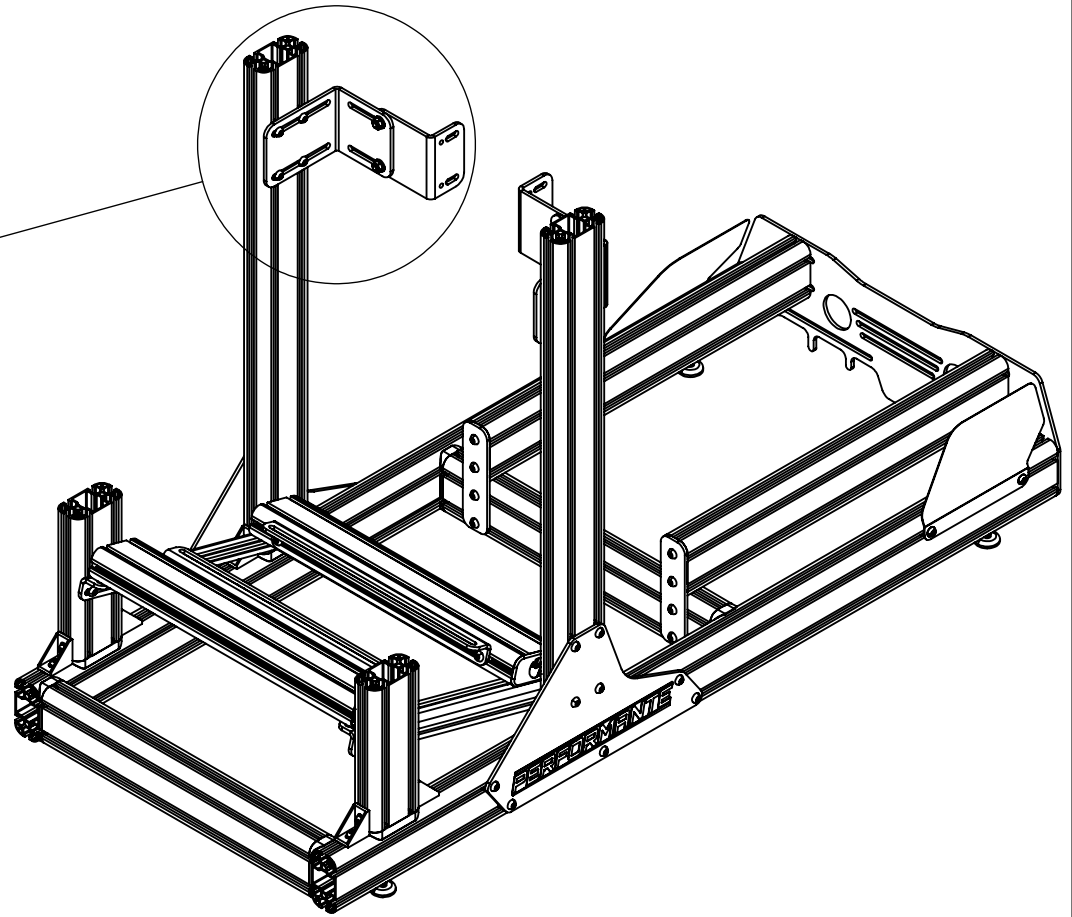
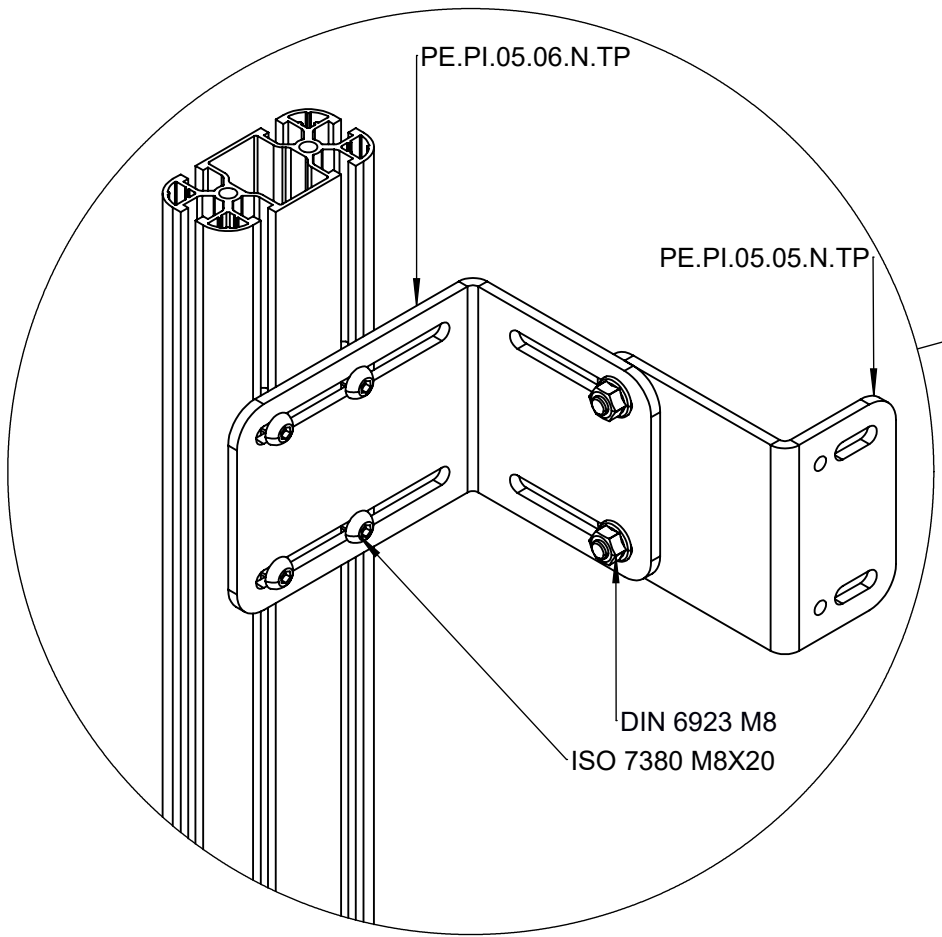

4X
DIN 6923 M8



8X
COD.DDDCU0000037



12X
ISO 7380 M8X20

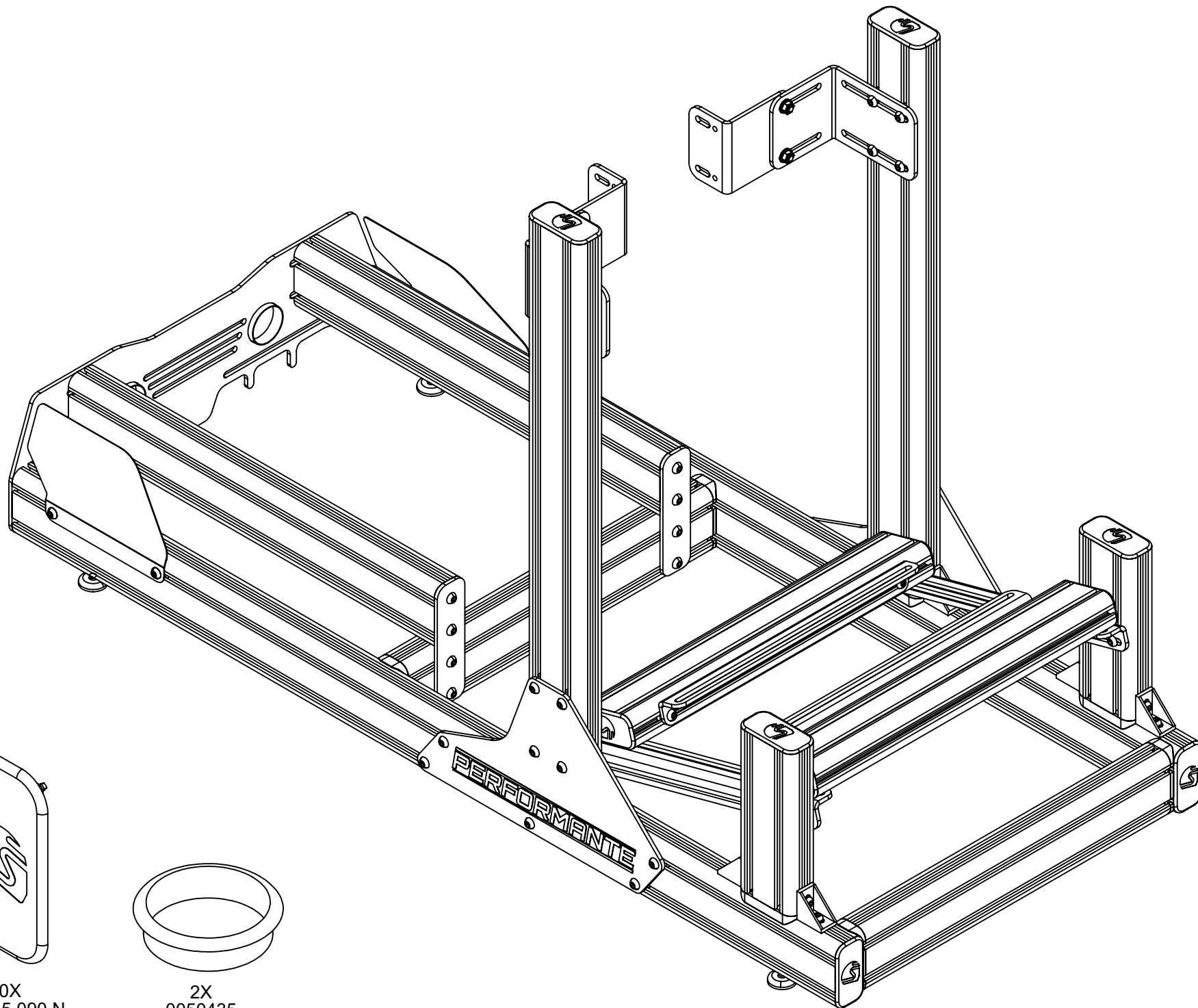

10X
TI.15.45.090.N

2X
0050435