

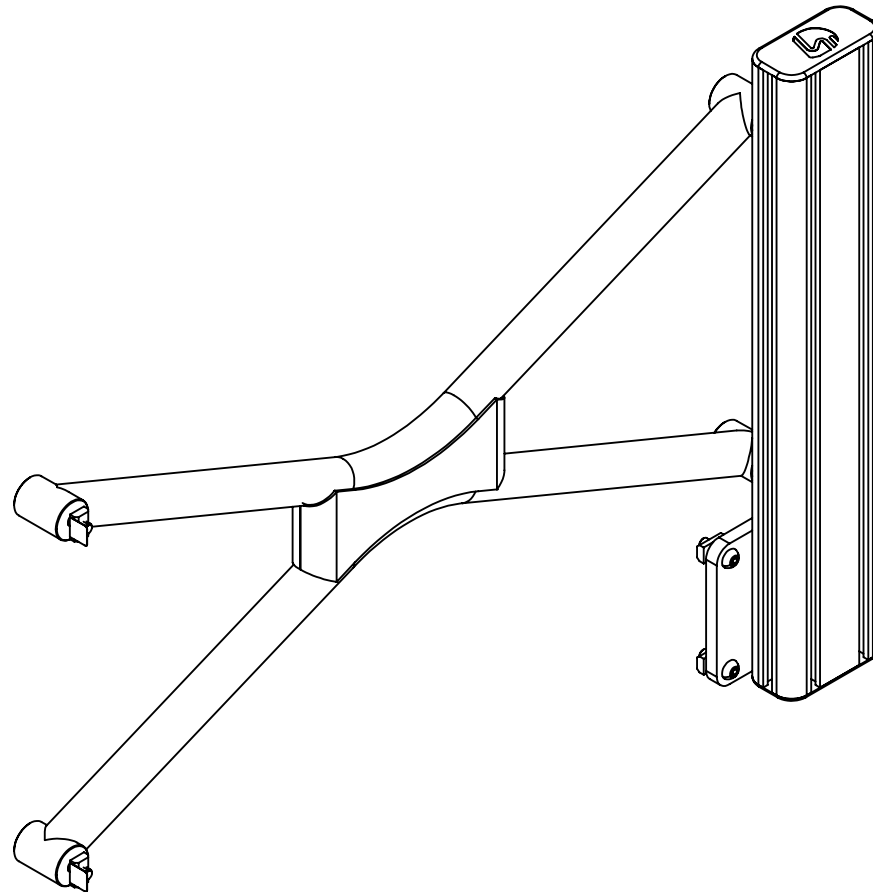

MANUALE DI ISTRUZIONI - INSTRUCTION MANUAL



ROLL BAR COMPETIZIONE

PRIMA DI PARTIRE:

ITA- Grazie per aver acquistato questo prodotto Sim Factory!
Nelle pagine seguenti troverete istruzioni dettagliate sull'assemblaggio.
Ciò richiede degli strumenti semplici e un po' del vostro tempo.

A seconda del prodotto scelto l'assemblaggio può richiedere da qualche minuto a molte ore, ma adorerete ogni minuto speso per dar forma al vostro prodotto Sim Factory.

BEFORE YOU START:

ENG- Thank you for purchasing this Sim Factory product!
On the following pages, you will find detailed instructions on assembly.
This requires only a set of simple tools and some of your time.

Depending on the product chosen assembly can take from a few minutes to many hours, but you will love every minute spent on shaping your Sim Factory product.

ITA- Strumenti necessari:

ENG- Tools needed:

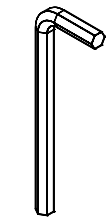

4mm
5mm
6mm

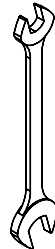

13mm
17mm

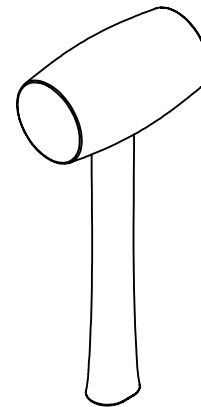

martello in gomma
rubber hammer

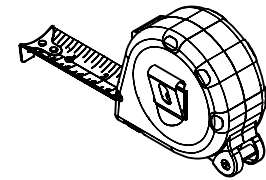

Inserimento cursori:

ITA- In questo diagramma potete vedere come inserire un cursore direttamente nella cava. Potete anche usare una delle chiavi esagonali più piccole per aiutarvi a muovere il cursore in posizione.

Inserting Slot-Nuts:

ENG- In this diagram, you can see how to insert a Slot-Nut directly into the slot from the side. You can also use one of your smaller Hex wrenches to help wiggle the Slot-Nut in place.

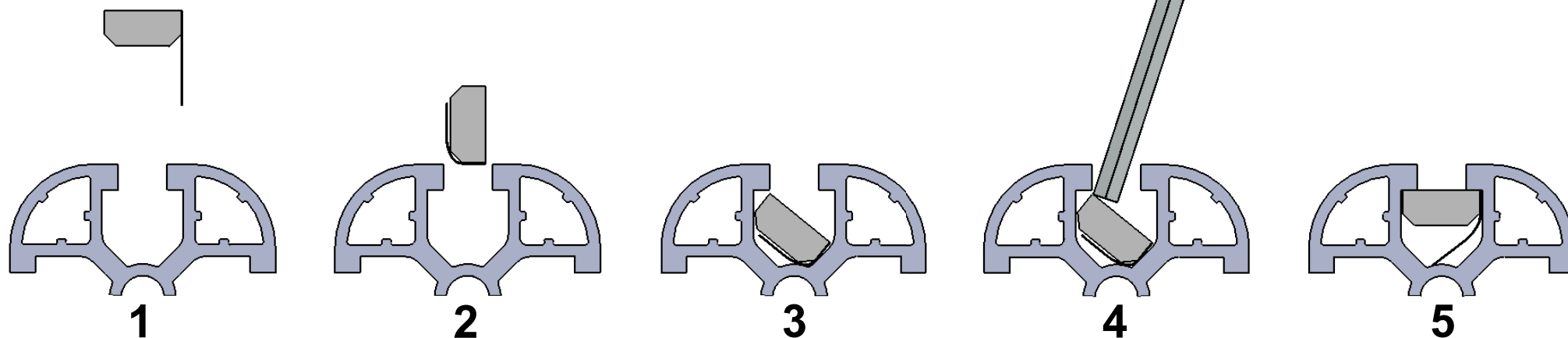
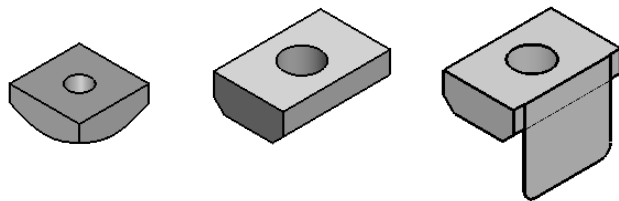

Foro passaggio chiave:

ITA- In questo diagramma potete vedere come eseguire il fissaggio correttamente.

Hex wrenches passage hole:

ENG- In this diagram, you can see how to fixing correctly.

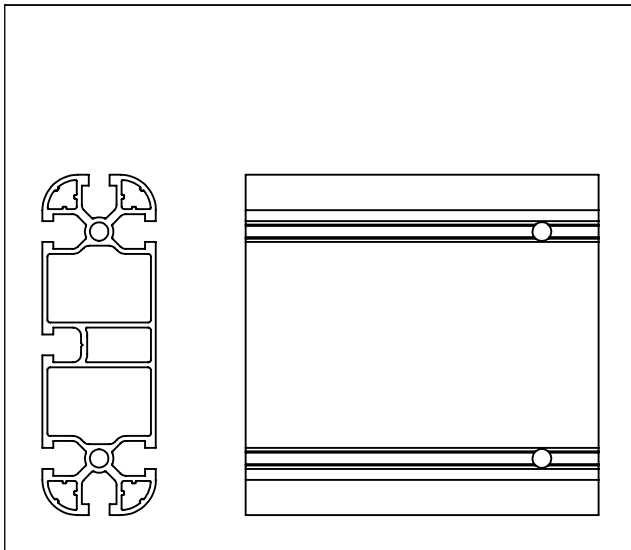
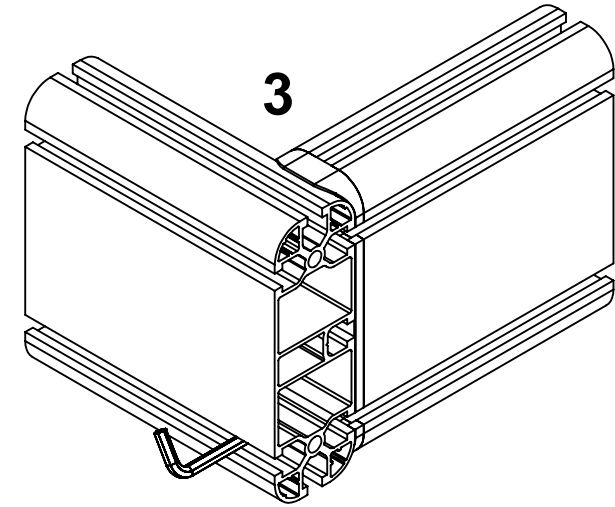
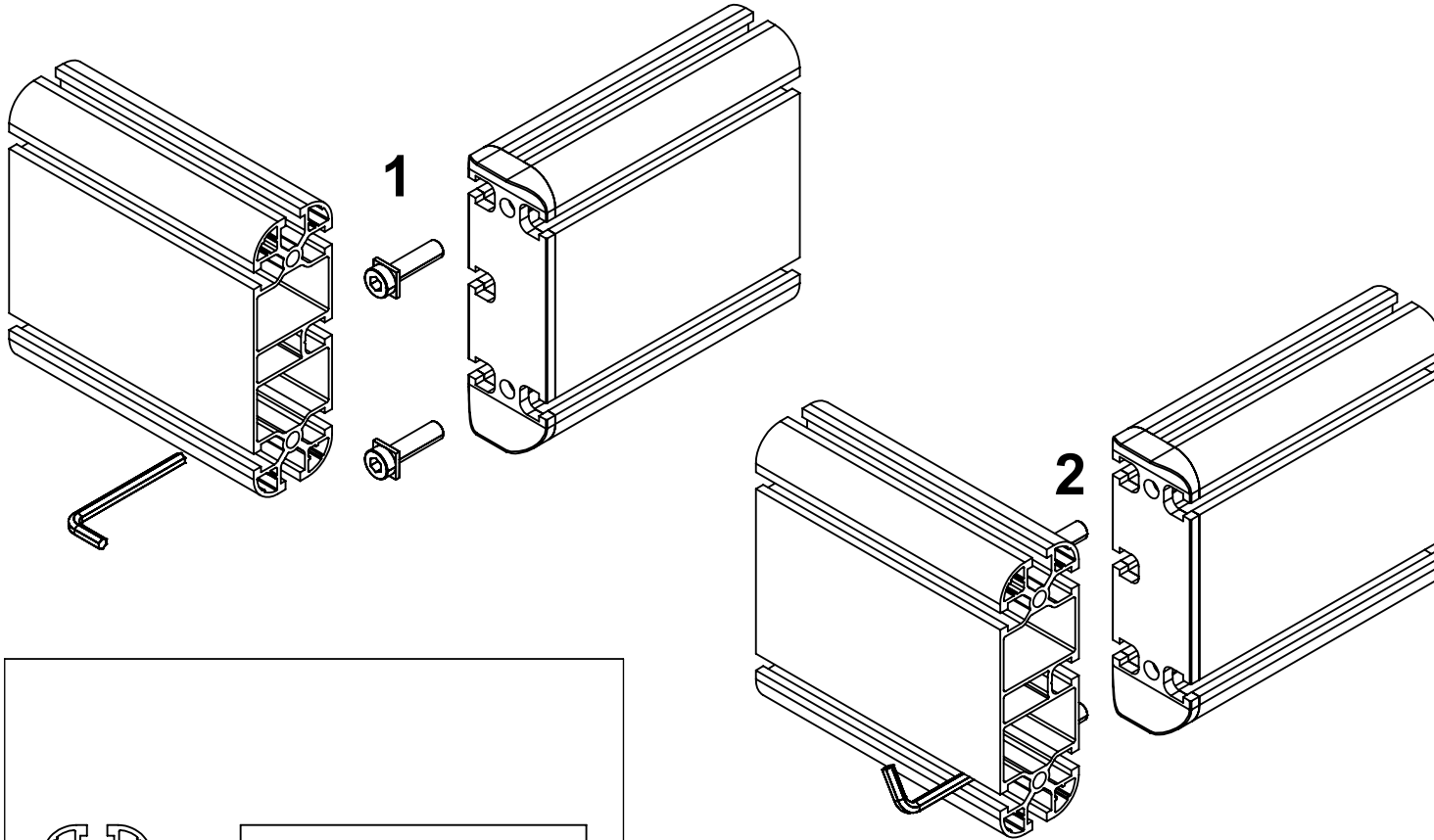

ITA- Vite a testa ribassata
ENG- Low head screw

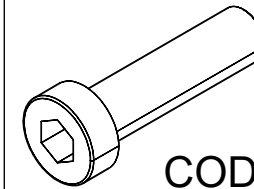

COD.CVITB0000023

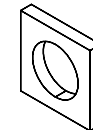

COD.CROY0000013

Foro passaggio chiave:

ITA- In questo diagramma potete vedere un altro modo per eseguire il fissaggio.

Hex wrenches passage hole:

ENG- In this diagram, you can see another way to do the fixing.

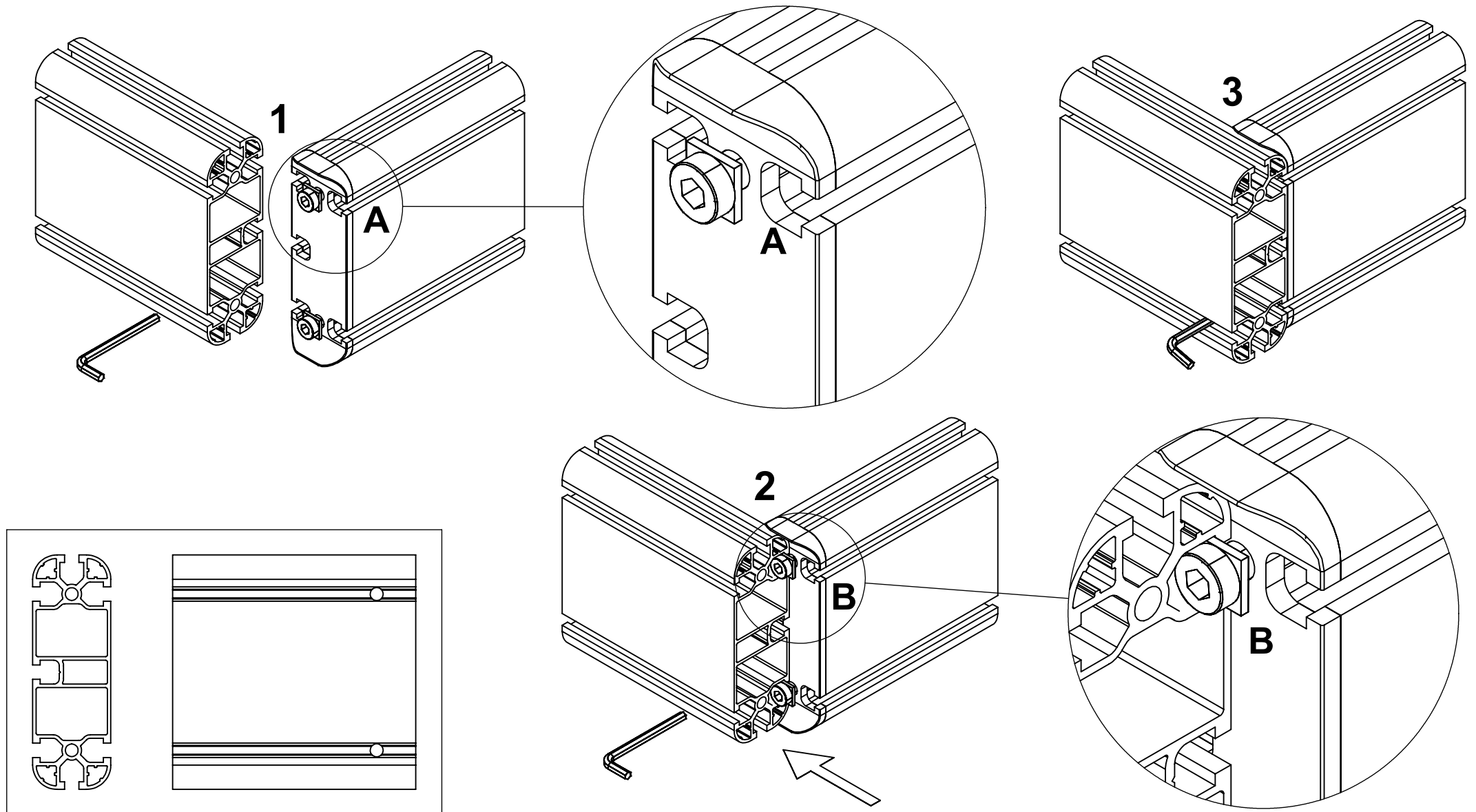

Inserimento tappi e giunti:

ITA- In questo diagramma potete vedere come inserire un tappo o un giunto. Potete anche usare il martello in gomma per incastrare il tappo o il giunto. Colpite la parte piatta del giunto, non occorre molta forza.

Inserting caps and joints:

ENG- In this diagram, you can see how to insert a cup or joint. You can also use the rubber hammer to tap in the cap or joint. Hit the flat part of the joint, it doesn't take much force.

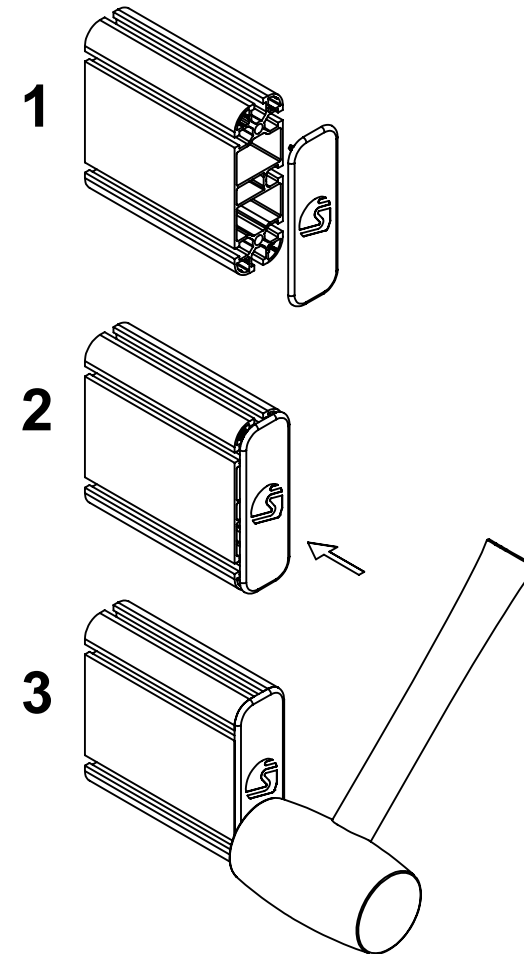
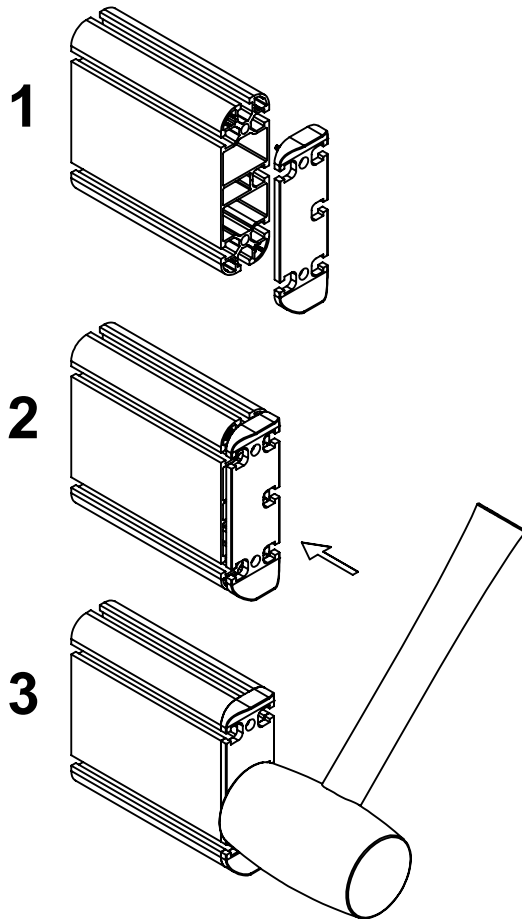

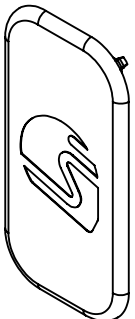
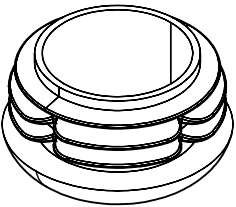
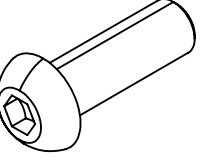
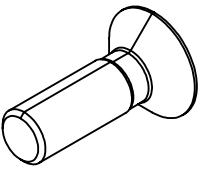
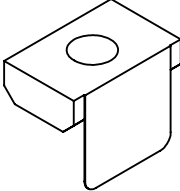
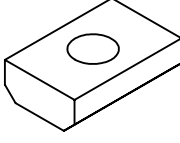
| | | | | | |
|---|---|--|---|---|---|
| <p>TI.15.45.090.N 2 PZ</p> <p>SA.02.COP.01</p> | <p>LSL 00700700028N 4 PZ</p> <p>SA.02.COP.01</p> | <p>ISO 7380 M8X25 8 PZ</p> <p>SA.01.COP.01</p> | <p>UNI 5933 M8X25 4 PZ</p> <p>SA.01.COP.01</p> | <p>M8 13X20X6 COD.DDDCU0000038 4 PZ</p> <p>SA.01.COP.01</p> | <p>M8 13X20X6 COD.DDDCU0000037 8 PZ</p> <p>SA.01.COP.01</p> |
|  |  |  |  |  |  |
| | | | | | |
| | | | | | |

ITA- COSA C'È NELLA SCATOLA
ENG- WHAT'S IN THE BOX

DIM: 80 X 55 X H 20
WEIGHT: 4,3 KG

COD. KI.COP.01.NO

CO.CA.RO.S.O **1PZ**

PR.090.N.L500.ST **1PZ**

CO.PI.10.03.N.SV **1PZ**

SA.01.COP.01 :

ISO 7380 M8X25 **8PZ**

UNI 5933 M8X25 **4PZ**

COD.DDDCU0000038 **4PZ**

COD.DDDCU0000037 **8PZ**

SA.02.COP.01 :

TI.15.45.090.N **2PZ**

LSL 00700700028N **4PZ**

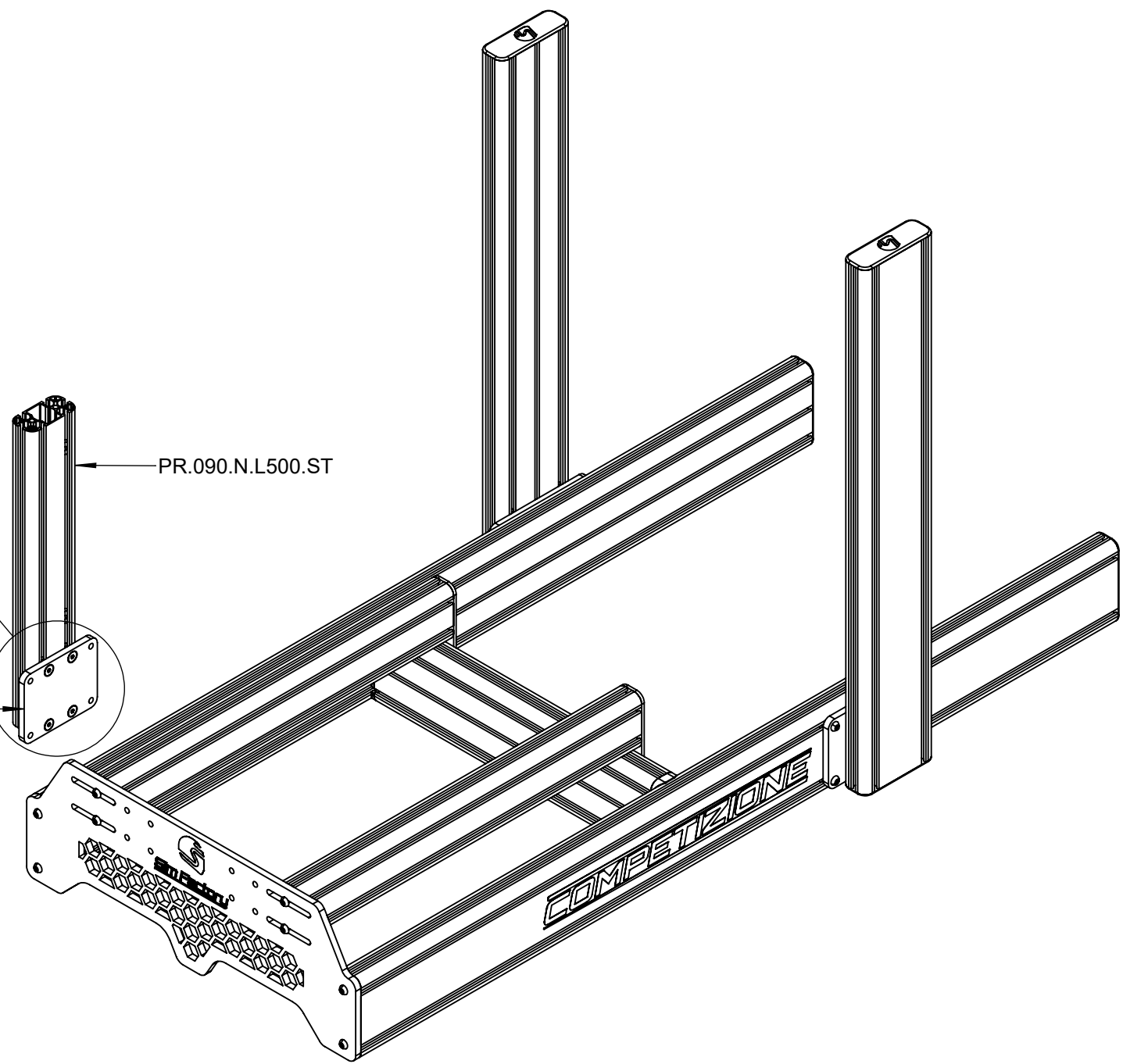
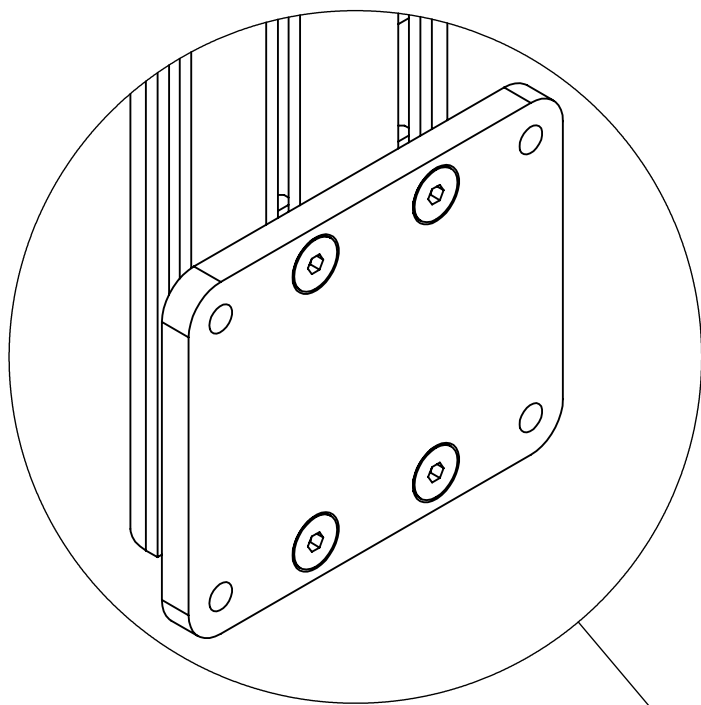

PR.090.N.L500.ST

CO.PI.10.03.N.SV

COMPETIZIONE



4X
COD.DDDCU0000037

4X
UNI 5933 M8X25

ITA- Roll Bar Competizione può essere installato dal lato destro o sinistro.

ENG- Roll Bar Competizione can be installed on the right or left side.

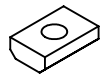
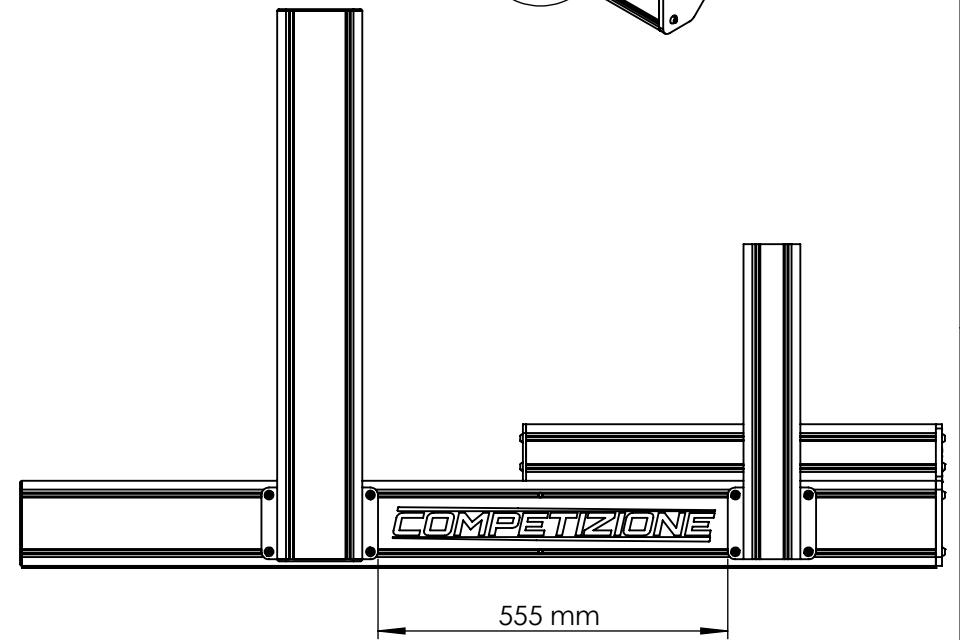
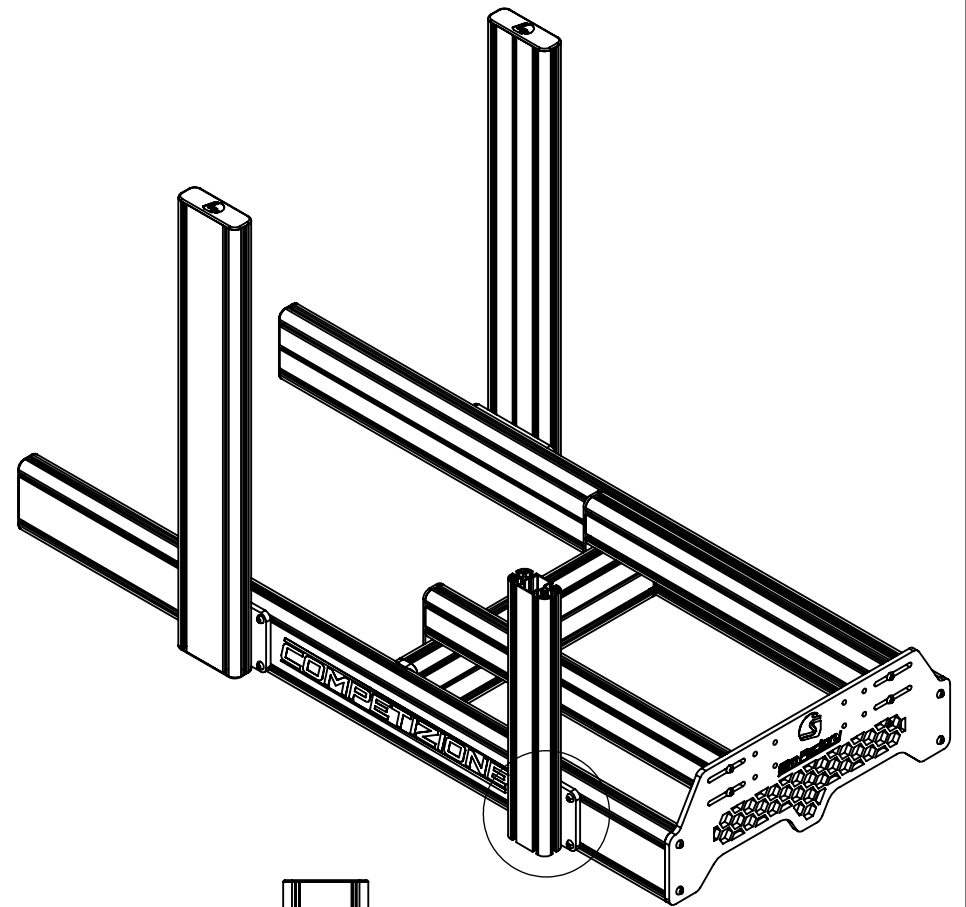
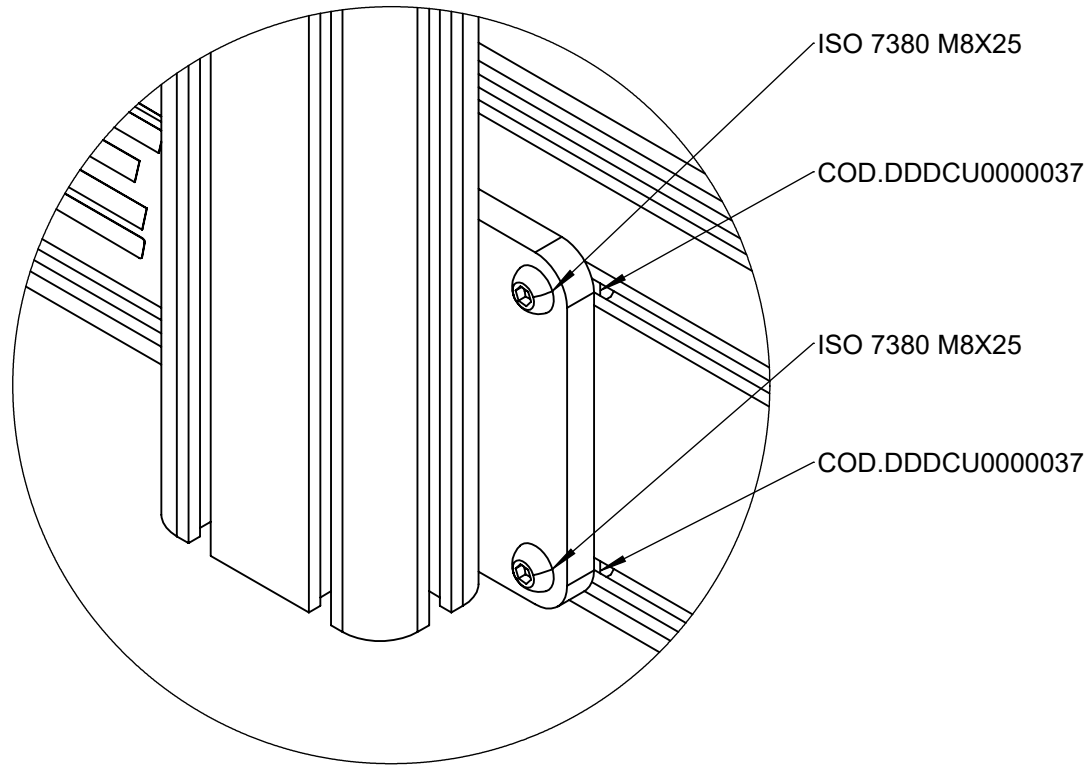

4X
COD.DDDCU0000037

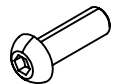

4X
ISO 7380 M8X25

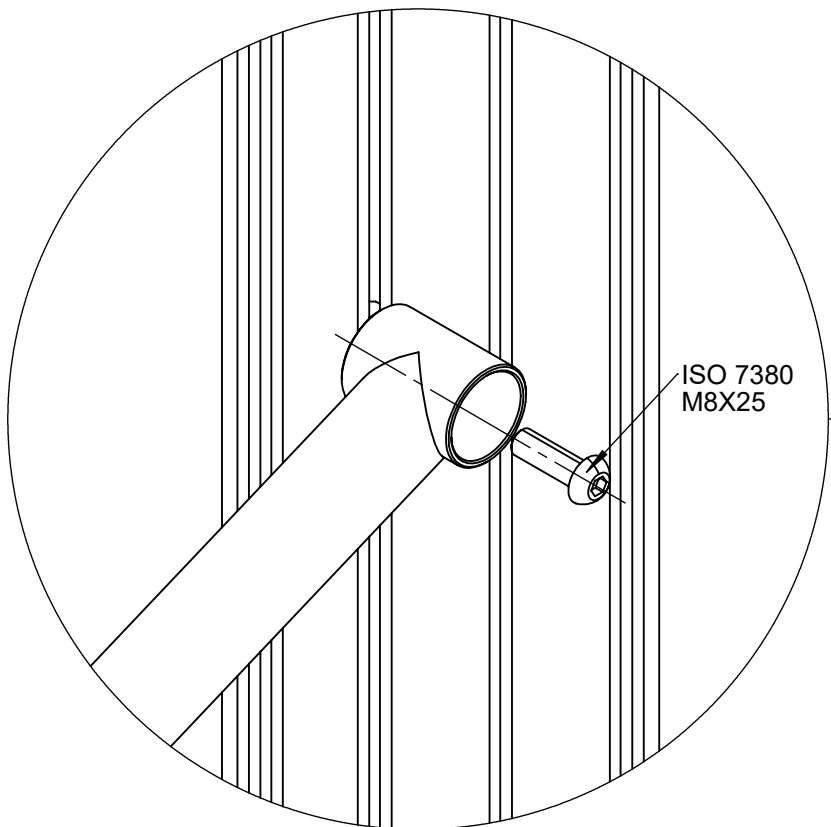

ISO 7380
M8X25

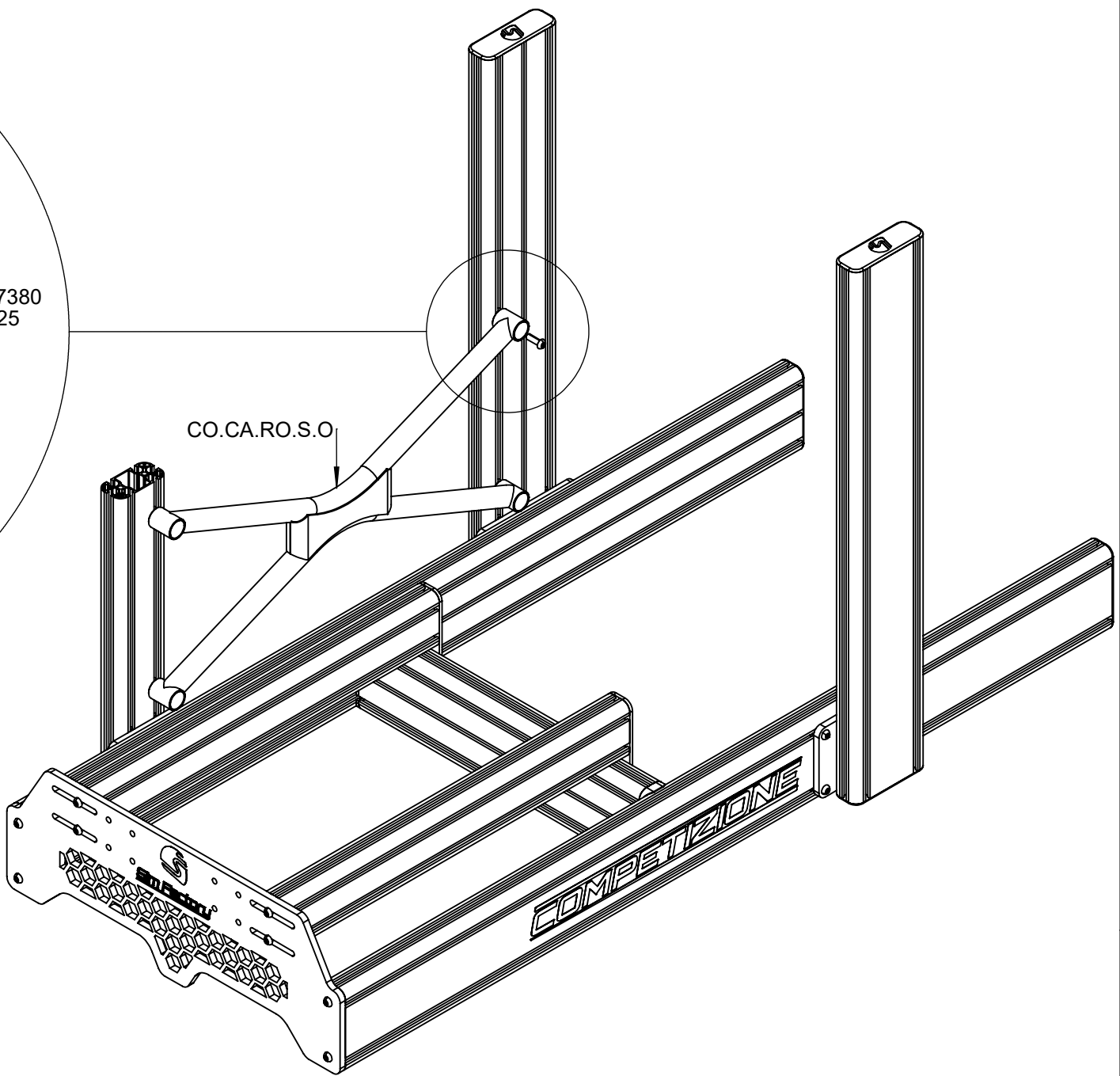

CO.CA.RO.S.O.

COMPETIZIONE

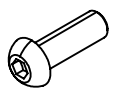

4X
ISO 7380 M8X25

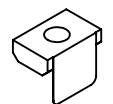

4X
COD.DDDCU0000038

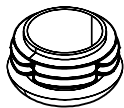
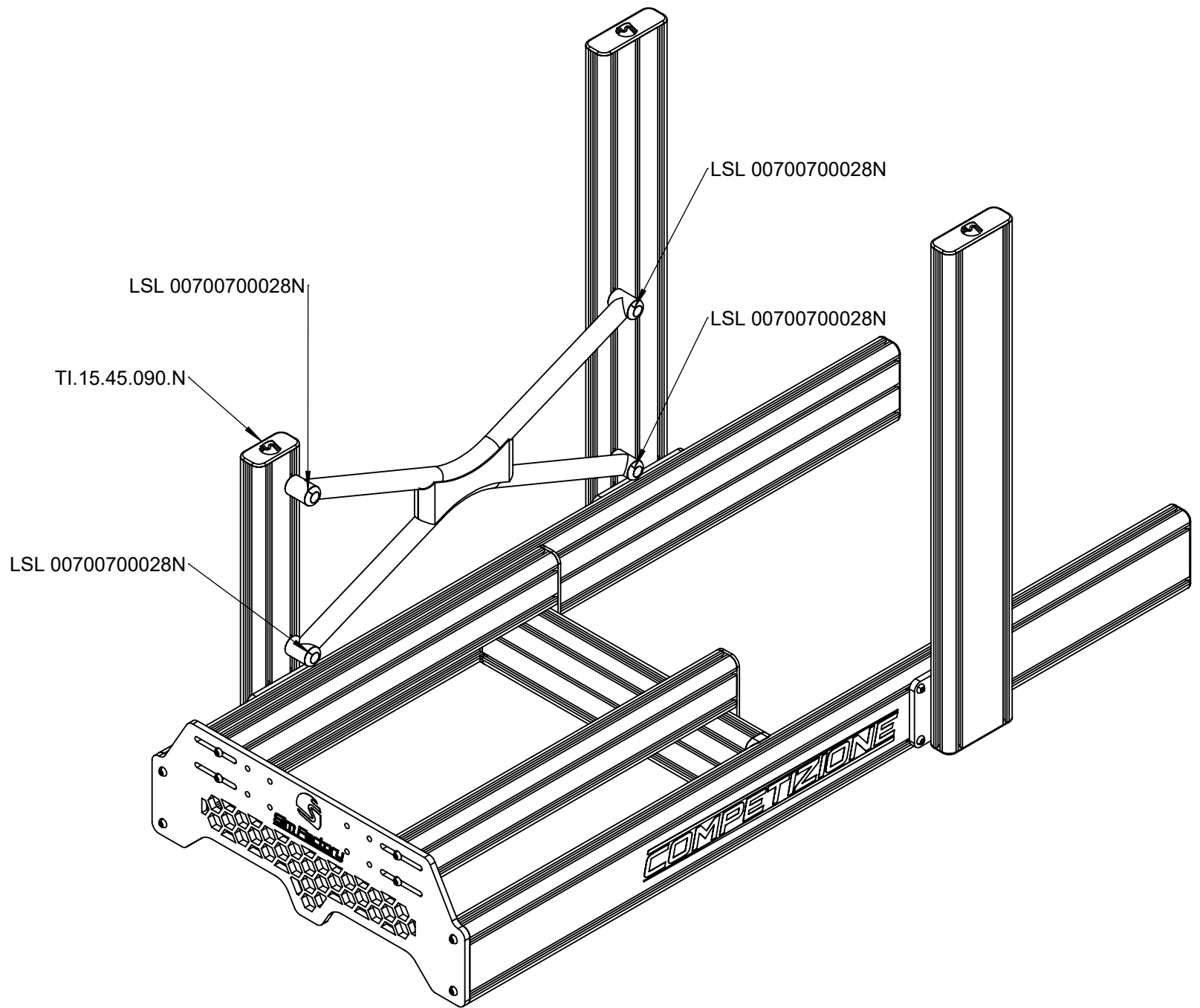

4X
LSL 00700700028N

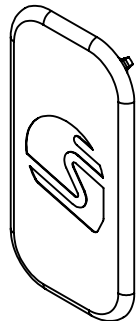

2X
TI.15.45.090.N